

Emotron VSA Variable Speed Drive



Instruction manual
English

emotron®

DEDICATED DRIVE

Quick Start Guide

This guide is designed to assist in installing and running the variable speed drive to verify that the drive and motor are working properly. Starting, stopping and speed control will be from the keypad. If your application requires external control or special system programming, consult the VSA Instruction Manual supplied with your variable speed drive.

Step 1 Before starting the VSD

Please refer to the chapters Preface and Safety Precautions in the VSA Instruction Manual. Verify that the drive is installed in accordance with the procedures described in the chapter Environment description and installation. If not, do not start the drive until qualified personnel have corrected the installation. (Failure to do so could result in serious injury.)

- Check VSD and motor nameplates to determine that they have the same power and voltage ratings. (Ensure that full load motor current does not exceed that of the VSD.)
- Remove the terminal cover to expose the motor and power terminals.
 - a. Verify that AC power is wired to L1, L2, and L3.
 - b. Verify that motor leads are connected to T1, T2, and T3.
 - c. If a brake module is necessary, please connect terminal voltage of the braking unit to + and - of the VSD.

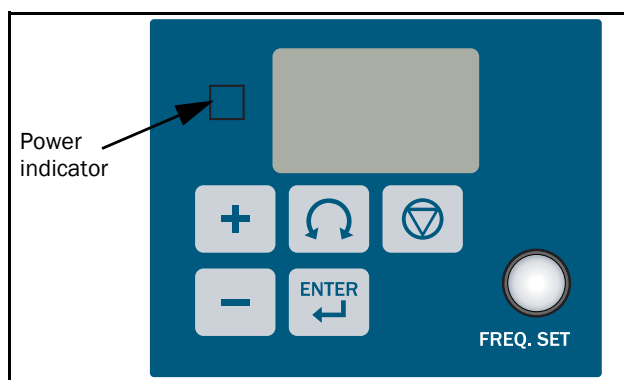



Step2 Apply power to the drive





Apply AC power to the drive and observe operator. Three 7-segment display should show power voltage for 3 to 5 seconds and observe how it runs, factory sets 5.00. (Frequency Command of 7-segment display should be flashed all the time.)

Step3 Check motor rotation under no-load conditions

- Press the  key. The 7-segment display will indicate the output frequency 00.0 to 05.0 Hz.
- Check the operation direction of the motor.

- If the direction of the motor is incorrect:
- Press the  key, turn off the AC power supply. Once Power indicator LED is off, change over the T1 and T2.
- Apply power again and press the  key and check the motor operation direction.

Step4 Check full speed at 50Hz/60Hz

- Change the frequency with the  or  and please press the  key to confirm the setting.
- Set frequency to 50Hz/60Hz according to the above regulations.
- Press the  key, inspect the motor operation as motor accelerates to full load.
- Press the  key, inspect the motor operation as motor deceleration.

Step5 Other settings

As for other function, please refer to VSA user manual.

Set acceleration time, page 37

Set deceleration time, page 37

Set upper frequency limit, page 38

Set lower frequency limit, page 38

Set motor rated current, page 32

Set control mode (Vector, V/F), page 30

Step6 vector Mode Settings

When the VSD is set to run in Vector Mode (211=000), the motor parameters needs to be set. The required information should be readily available on the nameplate of the motor. (Motor kW=0.75 x HP)

The parameters to set for vector operation:

Motor Rated Current (Amps) [223], see page 32

Motor Rated Voltage (Volts) [221], see page 32

Motor Rated Frequency (Hz) [224], see page 32

Motor Rated Power (KW) [222], see page 32

Motor Rated Speed (RPM) [225], see page 32

Additional Vector Mode Settings to adjust for optimum operations are:

Torque boost gain [351], see page 39

Slip compensation gain [354], see page 41

Low Frequency Voltage Compensation [352], see page 39.

Preface

Preface

To extend the performance of the product and ensure personnel safety, read this manual thoroughly before using the variable speed drive (VSD). Should there be any problem in using the product that can not be solved with the information provided in the manual, contact your nearest Emotron distributor or sales representative who will be willing to help you.

Precautions

The VSD is an electrical product. For your safety, there are symbols such as “Danger”, “Caution” in this manual as a reminder to pay attention to safety instructions on carrying, installing, operating, and checking the VSD. Be sure to follow the instructions for maximum safety.



WARNING: Indicates a potential hazard could cause death or serious personal injury if misused.



CAUTION: Indicates that the VSD or the mechanical system might be damaged if misused.



WARNING: Do not touch any circuit boards or components if the charging indicator is still lit after the power off is turned off.

Do not wire when the VSD is electrified. Do not check parts and signals on circuit boards during the VSD operation.

Do not disassemble the VSD or modify internal wires, circuits and parts.

Earth the ground terminal of the VSD properly. As per 200 V class, earth to 100 Ohm and 400 V class, earth to 10 Ohm or below.



CAUTION: Do not perform a voltage test on parts inside the VSD. High voltage will easily destroy these semiconductor parts.

Do not connect the VSD's T1 (U), T2 (V) and T3 (W) terminals to an AC power supply.

CMOS ICs on the VSD's main board are susceptible to static electricity. Do not touch the main circuit board

Product Inspection

The variable speed drives have all passed the function test before delivery. Please check the following when you receive and unpack the VSD:

- The model and capacity of the VSD is the same as those specified on your order.
- Is there any damage caused by transportation, do not apply the power.
Contact Emotron's sales representatives if any of the above problems have occurred.

Earthing

The variable speed drive must always be earthed via the mains safety earth connection, indicated by “PE”.

Earth leakage current

This VSD has an earth leakage current which does exceeding 3.5 mA a.c. or 10 mA d.c. Therefore the minimum size of the protective earth conductor must comply with the local safety regulations for high leakage current equipment.

Residual current device (RCD) compatibility

This product cause a d.c. current in the protective conductor. Where a residual current device (RCD) is used for protection in case of direct or indirect contact, only a Type B RCD is allowed on the supply side of this product. Use RCD of 300 mA minimum.

Contents

Quick Start Guide	1
Preface	3
Contents	1
Safety Precautions	3
1. Model description.....	5
2. Mounting and installation of the VSA drive..	7
2.1 Environment	7
2.2 Mounting and installation.....	9
2.3 Wiring Rules.....	10
2.3.1 Notice for wiring	10
2.3.2 Options and wiring specifications	11
2.3.3 Precautions for peripheral applications	12
2.4 VSD Specification.....	14
2.4.1 Basic specification	14
2.4.2 General Specifications.....	15
2.5 VSA Wiring diagram.....	17
2.6 Description of VSD Terminal	18
2.7 Dimension.....	19
2.8 Installation and design consideration	21
3. Programming instructions and menu list..	23
3.1 Keypad description	23
3.1.1 Keypad display	23
3.1.2 Operating Instructions for the keypad	23
3.2 The display.....	24
3.3 Menu function list	24
3.4 Menu function description	30
4. Troubleshooting and maintenance	57
4.1 Trouble indication and corrective action	57
4.1.1 Fault/ Error display and Diagnostics	57
4.1.2 Set up configuration, interface errors.....	58
4.1.3 Keypad operation error description	59
4.1.4 Load monitor error description	59
4.2 General functional troubleshooting.....	60
4.2.1 Troubleshooting flowcharts VSA series	61
4.3 Routine and periodic checks.....	67
5. Peripherals	69
5.1 Input side AC reactor	69
5.2 Option card	69
5.2.1 RS-485 option card.....	69
5.2.2 RS-232 option card.....	69
5.2.3 Program copy option card.....	70
5.2.4 Remote keypad	70
5.2.5 Input/Output expansion card.....	71
6. Appendix VSA parameter list.....	73

Safety Precautions

Operation Precautions

Before Power Up



The line voltage applied must comply with the VSD's specified input voltage. (See the nameplate)



WARNING: Make sure the main circuit connections are correct. L1, L2 and L3 are power-input terminals and must not be mistaken for T1, T2 and T3. If they are, the VSD might get damaged.



To avoid the front cover from disengaging, or other damage, do not carry the inverter by its covers. Support the drive by the heatsink when transporting. Improper handling can damage the inverter or injure personell and should be avoided.

To avoid fire, do not install the VSD on a flammable object.

If several VSD's are placed in the same control panel, assure that the temperature stays below 50 ° C to avoid overheating or fire.

During Power Up



The VSD will still stay live immediately after power loss. When the power is re-stored, the VSD operation is controlled by [252].

The VSD operation is controlled by [213] and [335] and the status of (FWD/REV RUN switch) when power is re-stored. [33A] / [226]) Power loss ride through/Auto reset after fault).

1. When [213]=000, the VSD will not auto restart when power is re-stored.
2. When [213]=001 and operation switches (FWD/REV RUN) is OFF, the VSD will not auto restart when power is re-stored.
3. When [213]=001 and operation switch ON and [335]=000, the VSD will auto restart when power is re-stored. Please turn OFF the run (start) switch to avoid damage to machine and injury to personnel before the power is re-stored.

When [335]=000 (direct start on power up), please refer to the description and warning for [335] to verify the safety of operator and machine.

Before operation



CAUTION: Make sure the model and VSD capacity match the setting in menu [921].



CAUTION: Do not touch heat-generating components such as heat sinks and brake resistors.

Leakage current



WARNING: Warning! EV series built in Filter type leakage current can exceed the IEC standard limit of 3.5mA. Please ground the VSD as shown in figures 3.5 and 3.6.

Operation with ungrounded supplies:

Filtered VSDs CANNOT be used on ungrounded supplies. Unfiltered VSDs can be used on ungrounded supplies. If any output phase is shorted to ground, the VSD may trip with OC.(over current trip)

Operation with Residual Current Device (RCD):

A filtered VSD with the trip limit of the RCD is 300 mA
The neutral of the supply is grounded, as is the VSD.
Only one VSD is supplied from each RCD.

The VSD can drive the motor from low speed to high speed. Verify the permitted speed ranges of the motor and the associated machinery.

Note the settings related to the braking unit.

Do not check signals on circuit PCB while the VSD is running.



CAUTION: Allow a minimum of 5 minutes power down before attempting to disassemble or check the components within the drive.

During operation



WARNING: Do not connect or disconnect the motor while VSD is operating the motor. The VSD and the disconnect device can sustain damage from high levels of switch-off current transients.



CAUTION: When the VSD top dust cover has been removed the drive can be installed in a non-condensing environment with temperature ranging between -10°C to $+50^{\circ}\text{C}$ and relative humidity of 95% or less, but the environment should be free from water and metal dust.



WARNING: To avoid electric shock, do not take the front cover off while power is on.

The motor will restart automatically after stop when auto-restart function is enabled. In this case, care must be taken while working around the drive and associated equipment.

NOTE: The operation of the stop switch is different than that of the emergency stop switch. The stop switch has to be activated to be effective. The operation of the Stop command is different than that of the Emergency Stop command. The Stop command has to be switched ON (activated) to be effective, and be switched OFF (de-activated) when controlling the motor speed. The Emergency Stop command has to be switched OFF (de-activated) to become effective and needs to be ON (activated) to make normal operation possible.

1. Model description

VSD model

Model: VSA23-04

Input voltage

I/P: AC 1 PH

200-240V 50/60Hz

Output specifications

O/P: AC3PH 0~264V

1.6kVA 4.2 A

EMOTRON AB

VSA	23	047
Series	Input voltage	Rated output current
	23: 230V	01/03/04/07/10 A
	48: 460V	002/004/005 A

2. Mounting and installation of the VSA drive

2.1 Environment

The environment will directly affect the proper operation and the life of the VSD, so install the VSD in an environment that complies with the following conditions:

Ambient temperature: 14 to 122°F (-10 to 50°C)

Avoid exposure to rain or moisture.

Avoid smoke and salinity.

Avoid dust, lint fibres, and metal filings.

Avoid electromagnetic interference (soldering machines, power machine).

Avoid vibration (stamping, punchpress). Add a vibration-proof pad if the situation can not be avoided.

If several VSDs are placed in the same control panel, provide heat removal means to maintain the temperature below 50°C. See figure 3-1 for proper drive arrangement.

Avoid direct sunlight.

Avoid corrosive liquid and gas.

Keep away from radio active and flammable materials.

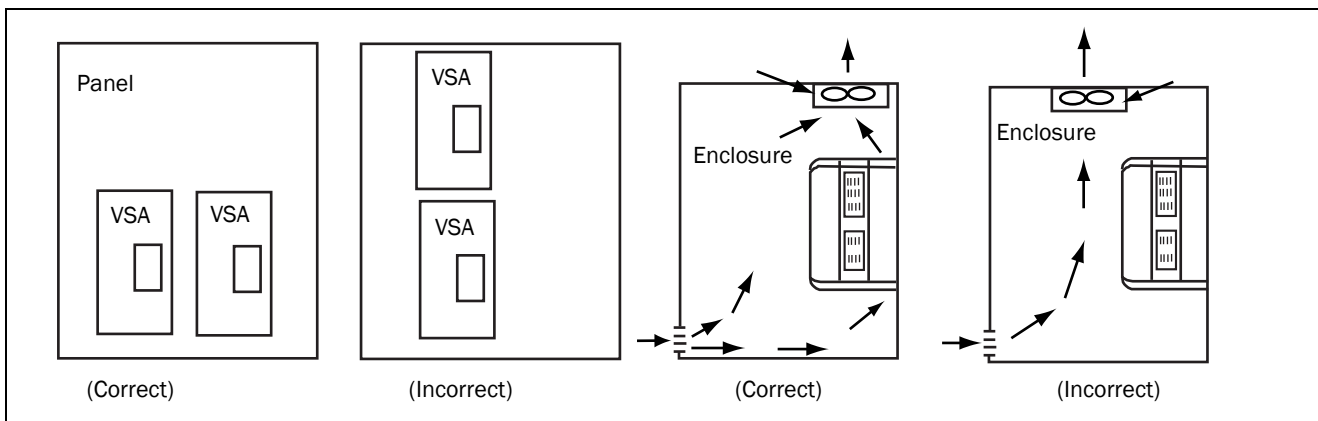

Fig. 1 Panel and enclosure arrangement for drives

Place the front side of the VSD outward and the top upward to improve heat dissipation.

- All VSA drives in IP-20 Enclosures can be DIN-RAIL mounted as shown below.

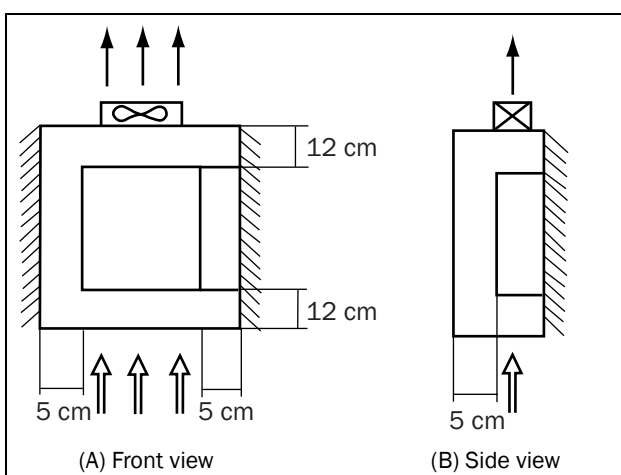

Fig. 2 Mounting and clearance requirements

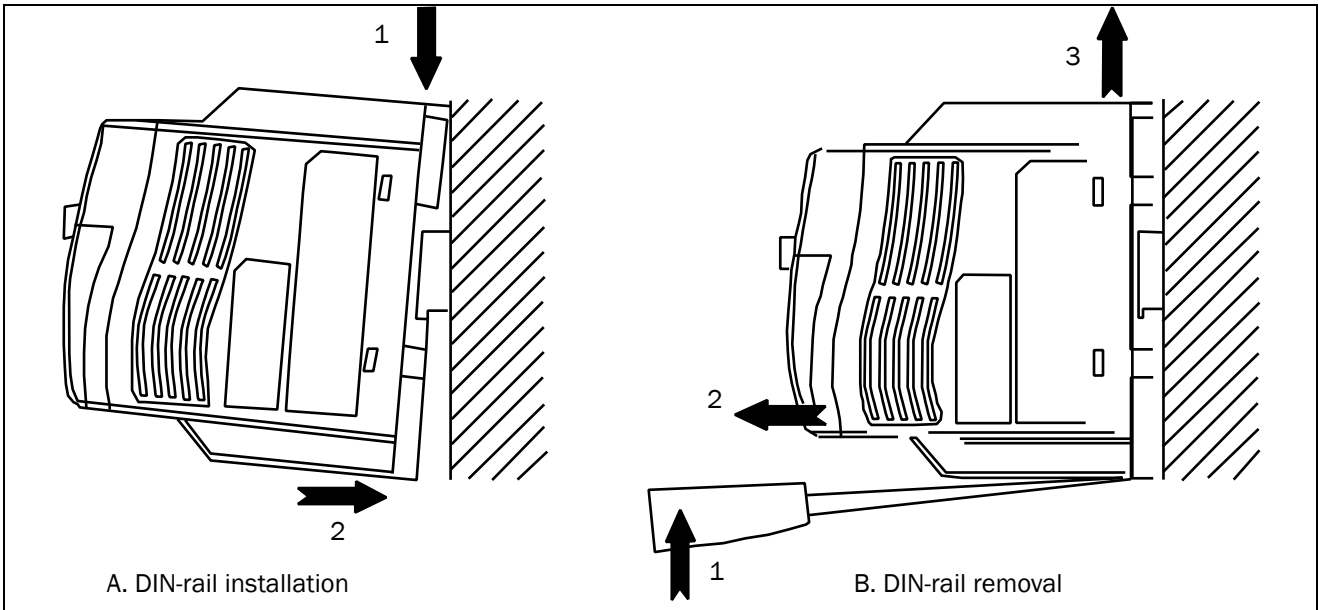

Fig. 3 DIN-rail mounting of the VSA drive

- All VSA drives in IP-20 enclosures can be mounted side-by-side as shown below. (ambient temperature below 122°F) (50°C).

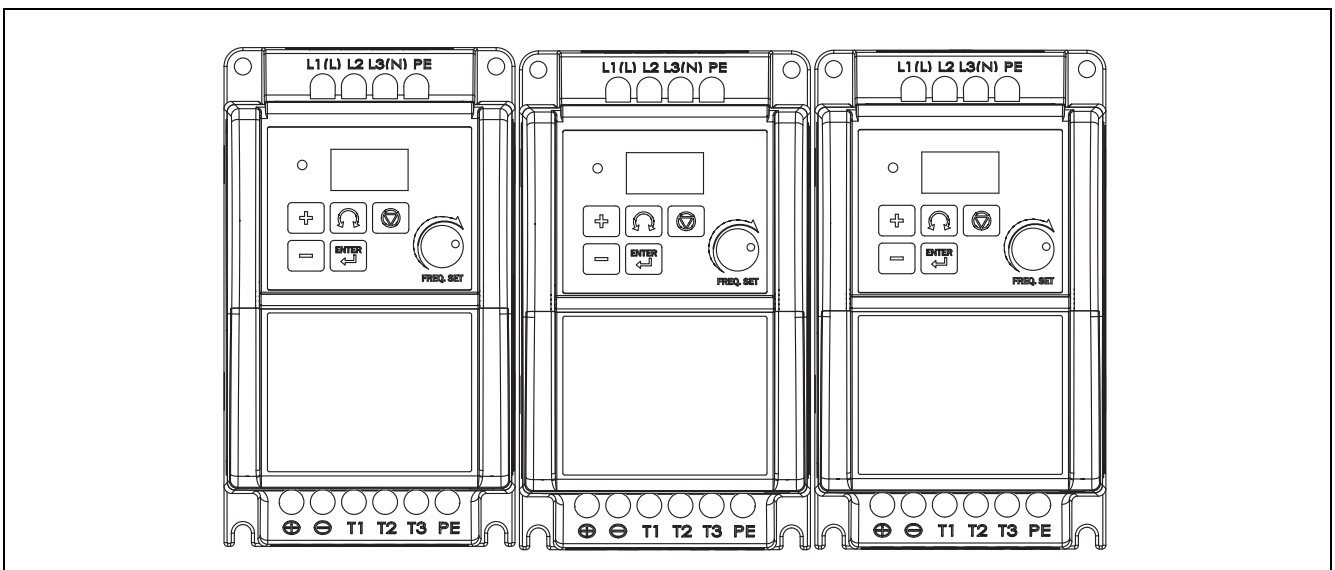

Fig. 4 Side-by-side Mounting of the VSA Drive

2.2 Mounting and installation

Do not use the VSD in an environment with the following conditions:

<p>Direct sunlight</p>	<p>Corrosive gas and liquid</p>	<p>Oil mist</p>
<p>Salt</p>	<p>Exposed to wind, rain and water</p>	<p>Iron filings, dust</p>
<p>Strong vibration</p>	<p>Extremely low temperatures</p>	<p>Excessively high temperatures</p>
<p>Electromagnetic waves and ultra high frequency waves (Near an electric welding machine)</p>	<p>Radioactive materials</p>	<p>Inflammable materials</p>

2.3 Wiring Rules

2.3.1 Notice for wiring

Tightening torque:

Connect cables with a screwdriver or other suitable tools per the tightening torques listed below.

Securing torque			
Type	Power source	Tightening torque for TM1 terminal	
VSA23-01/03/04	200-240V	0.74/0.1 (LBS-FT / KG-M)	8.66/10 (LBS-IN/KG-CM)
VSA23-07/10	200-240V	1.286/0.18 (LBS-FT/KG-M)	15.97/18 (LBS-IN/KG-CM)
VSA48-002/004/005	380-480V		

B. Power wires:

Power wires connect to terminals L1, L2, L3, T1, T2, T3, P and N. Select power wire in accordance with the following criteria:

1. Use wires with copper core only. Insulating materials with diameters should be based on working conditions at 221°F (105°C).
2. The minimum nominal voltage of 240 VAC type connectors is 300 V, and 480 VAC type connector is 600 V.

C. Control wire:

Control wire is connected to the TM2 control terminal. Select wire in accordance with the following criteria:

1. Use copper core only. The insulating materials with diameters should be based on working conditions at 221°F (105°C).
2. To avoid noise interference, do not route the control wiring in the same conduit with power wires and motor wiring.

D. Nominal electrical specifications of the terminal block:

The following are nominal values of TM1:

Type	Power source	Volts	Amps
VSA23-01/03/04	200-240V	600	15
VSA23-07/10	200-240V	600	40
VSA48-002/004/005	380-480V		

NOTE: Nominal values of input and output signals (TM2) – follow the specifications of class 2 wiring.

E. Fuse types

Drive input fuses are provided to disconnect the drive from power in the event that a component fails in the drive's power circuitry. The drive's electronic protection circuitry is designed to clear drive output short circuits and ground faults without blowing the drive input fuses. Below table shows the EV input fuse ratings.

To protect the VSD most effectively, use fuses with current-limit function.

RK5, CC/T type fuse for VSA

220V class(1φ)

VSA model	HP	kW	kVA	100% CONT Output AMPS (A)	Max. RK5 FUSE Rating (A)	Max. CC or T FUSE Rating (A)
VSA23-01	0.25	0.2	0.53	1.7	8	15
VSA23-03	0.5	0.4	0.88	3.1	10	20
VSA23-04	1	0.75	1.6	4.2	15	30
VSA23-07	2	1.5	2.9	7.5	20	40
VSA23-10	3	2.2	4.0	10.5	25	50

440V class(3φ)

VSA model	HP	kW	kVA	100% CONT Output AMPS (A)	Max. RK5 FUSE Rating (A)	Max. CC or T FUSE Rating (A)
VSA48-002	1	0.75	1.7	2.3	6	10
VSA48-004	2	1.5	2.9	3.8	10	15
VSA48-005	3	2.2	4.0	5.2	10	20

*Fuse ratings are based upon 300 V fuses for 230 V VSDs, and 500 V for 460 V VSDs

2.3.2 Options and wiring specifications

MCCB/ MC/ Fuse

- Warranty and replacement service does not apply to damage caused by the following conditions.

- MCCB or fuse is not installed, improperly installed, or improperly sized, and has resulted in VSD damage.
- MC or capacitor or surge absorber is installed between the VSD and the motor.

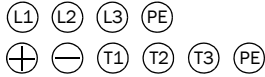
VSA model	VSA23				VSA48
	-01/-03	-04	-07	-10	
Fuse	10 A 300 VAC	20 A 300 VAC	30 A 300 VAC		15A/600 VAC
Main circuit terminal 	Wire dimension (14AWG) 2.0mm ² Terminal screw M4			Wire dimension (12 AWG) 3.5 mm ² Terminal screw M4	Wire dimension (14 AWG) 2.0 mm ² Terminal screw M4
Signal terminal (TM2) 1 to 12	Wire dimension (#18 AWG) 0.75 mm ² Terminal screw M3				

Use a single fuse for 1 L/N model. For 3 models, each L1/ L2/L3 phase must be fused.

- Please utilize three phase squirrel cage induction motor with appropriate capacity for VSD.
- If the VSD is used to drive more than one motor, the total capacity must be smaller than the capacity of the AC drive. Additional thermal overload relays must be installed in front of each motor.
- Do not install phase advancing capacitors, LC, or RC components between VSD and motor.

2.3.3 Precautions for peripheral applications

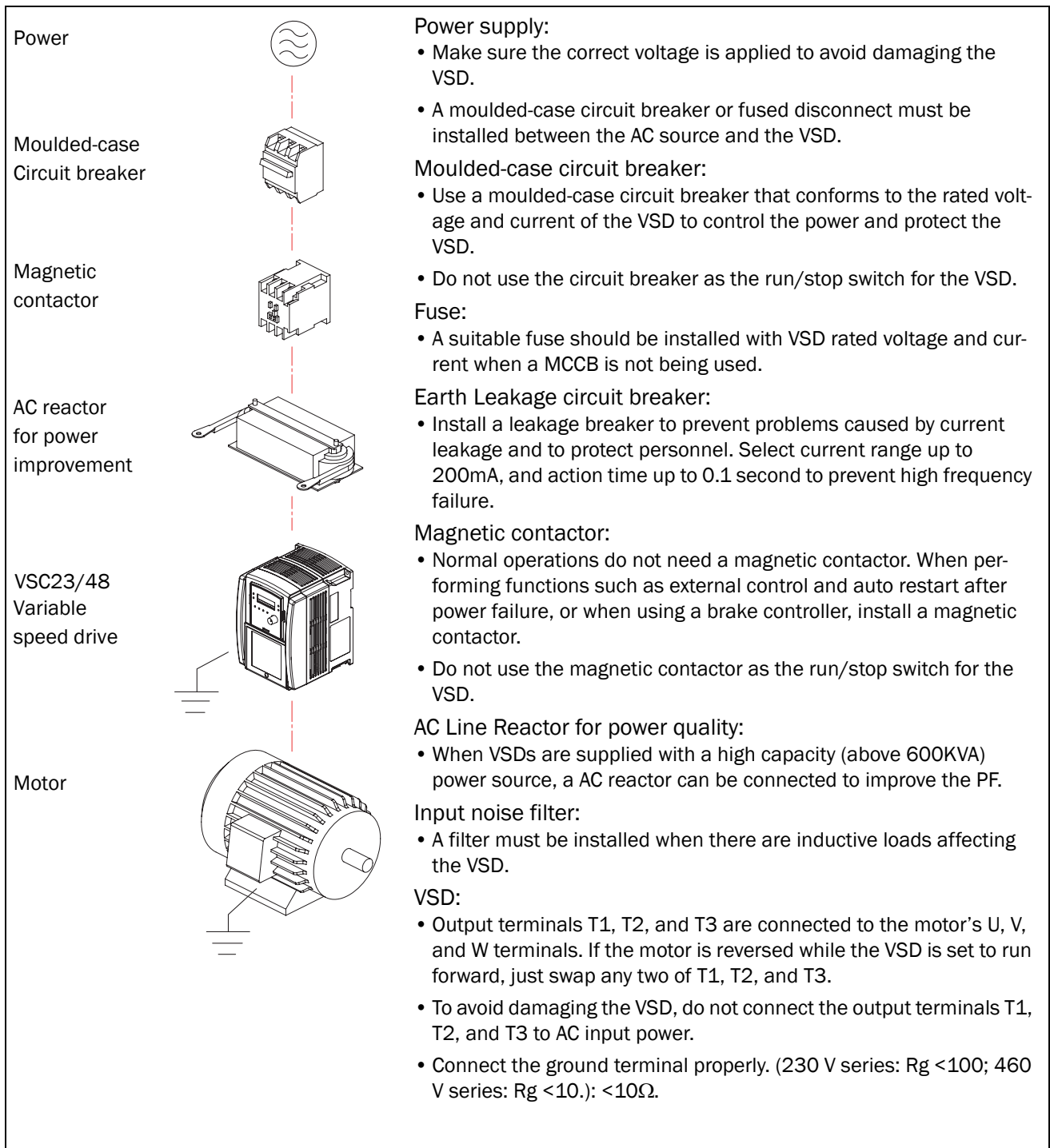

Fig. 5 Typical installation schematic

Make external connections as shown in figure 3-10. Check after wiring to make sure all connections are correct. (Do not use the control circuit buzzer to check connections)

(A) Main circuit must be separated from other high voltage or high current power line to avoid noise interference. Refer to following figures:

- A noise filter in the output of the main circuit can suppress conductive noise. To prevent radiative noise, the wires should be put in a ferromagnetic metal pipe and separated from all other signal lines by at least 1ft.

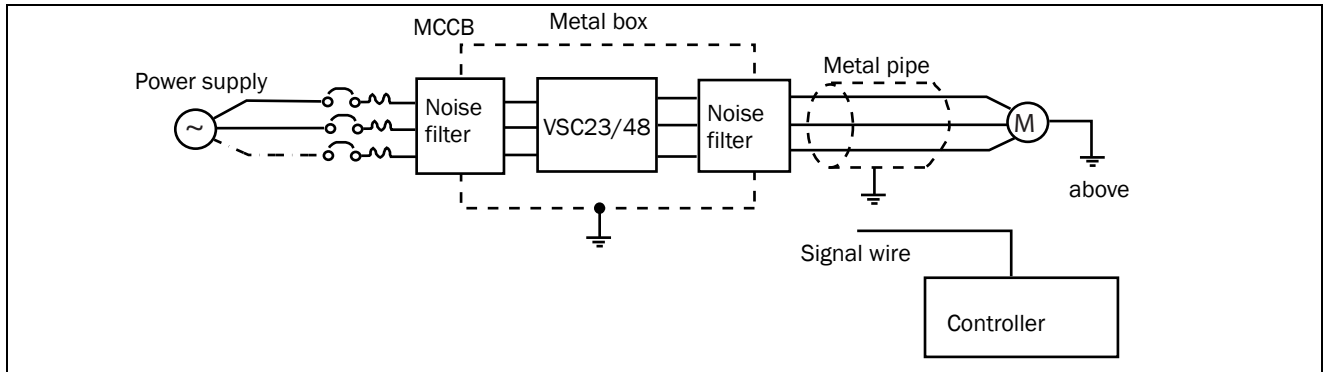

Fig. 6 Installation examples with adjacent signal conductors

- The power supply and output PE terminals must be both connected to ground to increase noise immunity of the built-in Filter.

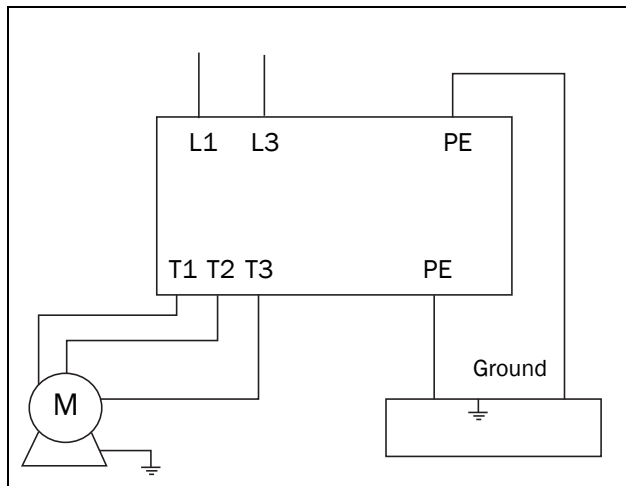

Fig. 7 Grounding filtered units

(A)The control circuit wiring and main circuit wire/ other high voltage/current power wiring should be separated to avoid noise interruption.

- In order to prevent noise interference which could cause VSD faults, the control circuit signal should be shielded and twisted. Please refer to fig. 8. The wiring distance should be less than 150ft (50m).

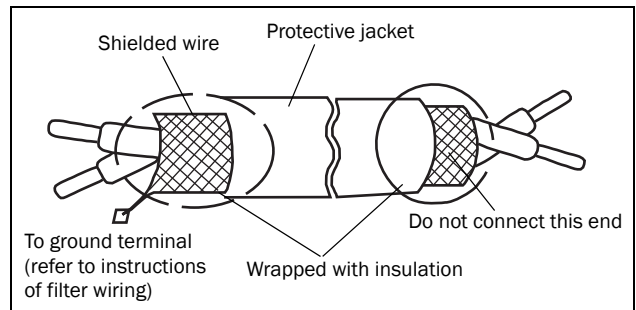
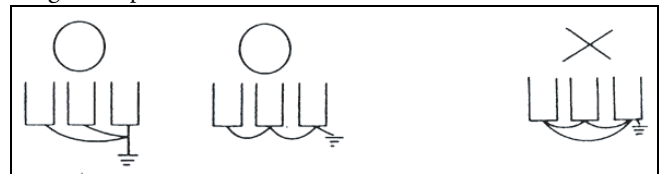

Fig. 8 Processing the ends of twisted pair cables

(B) Connect ground terminals as follows: (200 V class ground <100; 400 V class ground <10.)

- Ground wiring AWG is sized per the electrical equipment specifications and should be made as short as possible.
- Do not share the ground of the VSD with other high current loads (welding machine, high power motor). Connect the terminal to its own ground.
- Do not make a loop when several VSDs share a common ground point.



(a) Good (b) Good (c) Bad

Fig. 9 Grounding examples: multiple drives

(C) To ensure maximum safety, use correct wire size for the main power circuit and control circuit.

(See table in section 2.3.2, page 11)

(D) Verify that all wiring is correct, wires are intact, and terminal screws are secured.

- When the connection between the VSD and the motor is too long, consider the voltage drop of the circuit. Phase-to-phase voltage drop (V) = $3 \times \text{resistance of wire (}/\text{km)} \times \text{length of line (m)} \times \text{current} \times 10^{-3}$. And the carrier frequency must be adjusted based on the length of the line.

The length of the line between the VSD and the motor	Below 25 m	Below 50 m	Below 100 m	Over 100 m
Carrier Frequency	Below 16 kHz	Below 12 kHz	Below 8 kHz	Below 5 kHz
Settings in menu [226]	16	12	8	5

2.4 VSD Specification

2.4.1 Basic specification

Model	230 V model				
	Single phase VSA				
	23-01	23-03	23-04	23-07	23-10
Max.Applicable Motor output.HP*1 (kW)	0.25 (0.2)	0.5 (0.4)	1 (0.75)	2 (1.5)	3 (2.2)
Rated output current (A)	1.7	3.1	4.2	7.5	10.5
Rated capacity (kVA)	0.53	0.88	1.60	2.90	4.00
Input voltage range (V)	1PH, 200 to 240V+10%,-15%(50/60Hz)				
Output voltage range (V)	3PH 0 to 240V				
Input current (A)	4.3	5.4	10.4	15.5	21
VSD with filter weight kb (kg)	1.57 (0.71)	1.71 (0.73)	1.71 (0.73)	2.76 (1.25)	2.87 (1.3)
Maximum momentary power loss time (S)	1.0	1.0	1.0	2.0	2.0
Enclosure	IP20				

Model	460 V model		
	Three phase VSA		
	VSA48-002	VSA48-004	VSA48-005
Max.applicable Motor Output HP*1 (kW)	1.0 (0.75)	2.0 (1.50)	3.0 (2.2)
Rated output current (A)	2.3	3.8	5.2
Rated capacity (kVA)	1.7	2.9	4.0
Input voltage range (V)	3PH 380 to 480V+10%,-15% (50/60Hz)		
Output voltage range (V)	3PH 0 to 480V		
Input current (A)	3	4.8	6.6
VSD with filter Weight Lb. (kg)	3.70 (1.37)	3.75 (1.4)	3.82 (1.45)
Maximum momentary power loss time (S)	1.0	2.0	2.0
Enclosure	IP20		

* Based on a 4-Pole Motor

2.4.2 General Specifications

Frequency control	Range	0 to 200 Hz
	Initial Drive	100%/3 Hz (Vector mode)
	Speed Control Range	(Vector mode) 20:1
	Speed Control Precision	±0.5% (Vector mode)
	Setting resolution; see note 1	Digital: 0.1 Hz (0 to 99.9 Hz)/1 Hz (100 to 200 Hz); analogue: 0.06 Hz/ 60 Hz
	Keypad setting	Set directly with keys or the VR on the keypad
	Display	7 segment*3 Displays; frequency/DC Voltage/Output Voltage / Current/ VSD parameters/fault log/program version/PID feedback control potentiometer.
	External signal setting	<ul style="list-style-type: none"> • External • Performs up/down controls with multi-functional contacts on the terminal base
	Frequency limit function	Upper/lower frequency limits, and two skip frequencies.
General control	Carrier frequency	4 to 16 kHz (default 10 kHz, above 10 kHz with De-rating)
	V/F pattern	6 fixed patterns 50 Hz/60 Hz, 1 programmable
	Acc/Dec. control	Two-stage acc/dec time (0.1 to 999 s)
	Multi-functional analogue output	6 functions (refer to [531] description)
	Multi-functional input	19 functions (refer to [521] to [524] description)
	Multi-functional output	16 functions (refer to [551] description)
	DI (digital input)	NPN/PNP alternative: 4 points standard, 2 points optional (S1 to S4 standard, S5 to S6 optional)
	DO (digital output)	Relay output *Form A contact ---- set to multi-function output. External multi-function output *option 1 point (open collector transistor 24 V, 600 mA)
	AI (analogue input)	Set speed command and PID feedback signal (speed, PID 4–20 mA /0–10 V) or MFIT S7
	Other functions	Instantaneous power loss on restart, Speed search, fault restart, DC injection braking,
	Communication control	<ul style="list-style-type: none"> • RS485 Option card: Modbus RTU/ASCII mode, 4800 to 38400 bps, max. 254 stations
	Operation temperature	14 to 122°F (-10 to 50°C) IP20, 14 to 104°F (-10 to 40°C) IP65
	Storage temperature	-4 to 140°F (-20 to 60°C)
	Humidity	0 – 95% RH (non condensing)
	Vibration immunity	1G (9.8 m/s ²)
	EMI/EMS Compatibility	Built-in filter in accordance with EN61800-3 first environment
	LVD	Accordance with EN50178
Enclosure	IP20	
Safety Class	UL508C	

Protective Functions	Over load protection	VSD rated current 150%/1 min
	International conformity	UL/CE
	Over-voltage	230V Class: DC voltage >400 V 460 V Class: DC voltage >800 V
	Under-voltage	230V Class: DC voltage <190 V 460 V Class: DC voltage <380 V
	Instantaneous power loss restart	Set to enable or disable
	Stall prevention	ACC/DEC/ Operation stall prevention and stall prevention level.
	Output terminal short circuit	Electronic circuit protection
	Other faults	Electronic circuit protection
	Other functions	Over current, over voltage, under voltage, over load, instantaneous power loss restart, ACC/DEC/ Operation stall prevention, output terminal sort circuit, grounding error, reverse limit, directly start as power on and fault reset limit.

NOTE 1: The setting resolution of above 100 Hz is 1Hz when controlled by keypad, and 0.01 Hz when controlled using computer (PC) or programmable controller (PLC).

NOTE 2:

VSA23-01/03/04 type (Fc=10 kHz) and VSA23-07/10 type (Fc=6 kHz) with Build in filter complies with EN61800-3 first environment unrestricted distribution.

VSA48-002-005 type (Fc=10 kHz) with Build in filter complies with EN61800-3 first environment restricted distribution.

2.5 VSA Wiring diagram

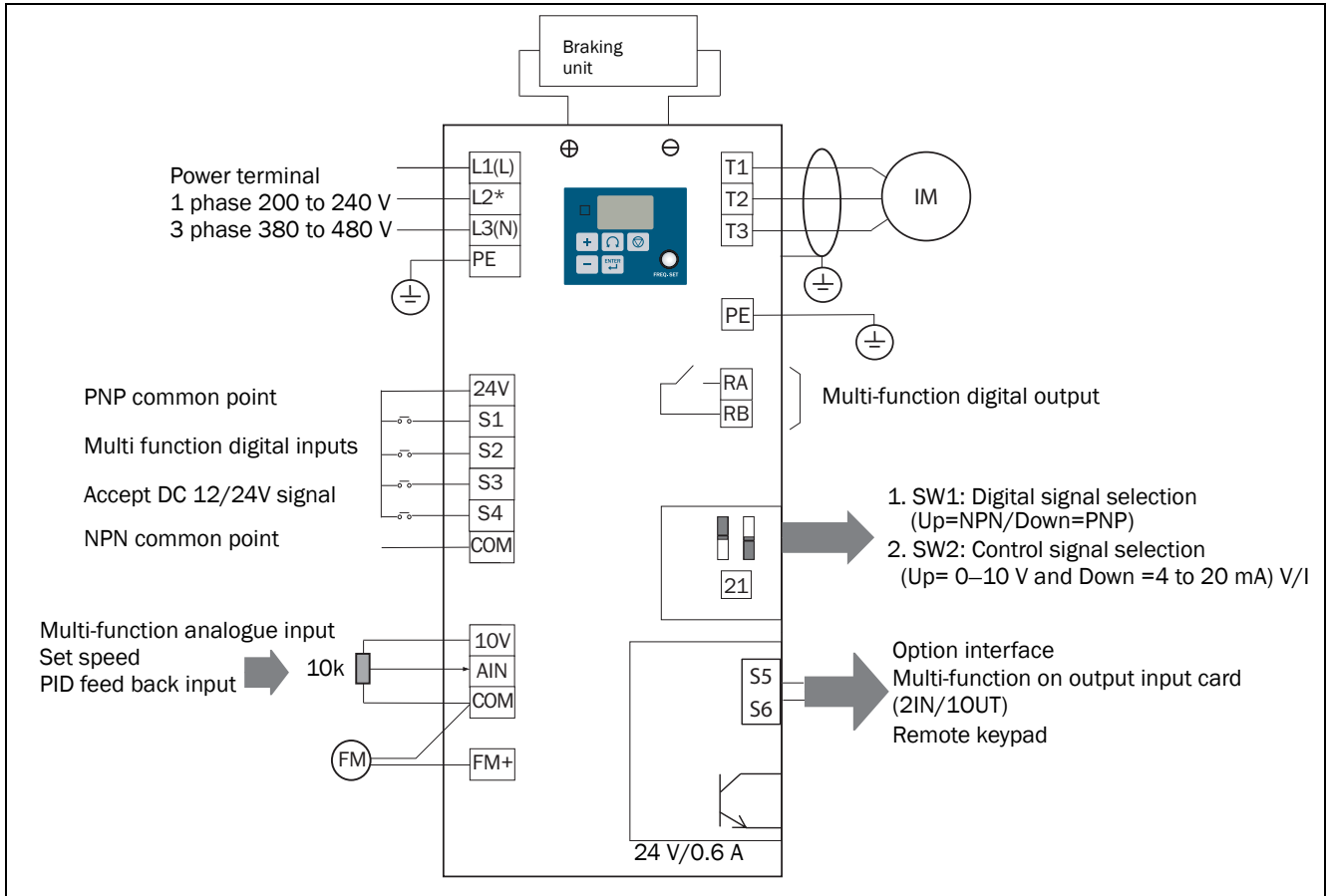

Fig. 10 Wiring diagram

NOTE 1: Connect inputs to Terminal 3 (internal 24vdc) for PNP mode (Positive switching).

Or to terminal 8 (Common) for NPN mode (Negative switching).

NOTE 2: External 24 VDC may be used to supply the external contacts at each input (Connect the 0V of the external supply to Common (terminal 8)).

NOTE 3: L2 is not used for single phase operation.

Example: Main circuit wiring diagram

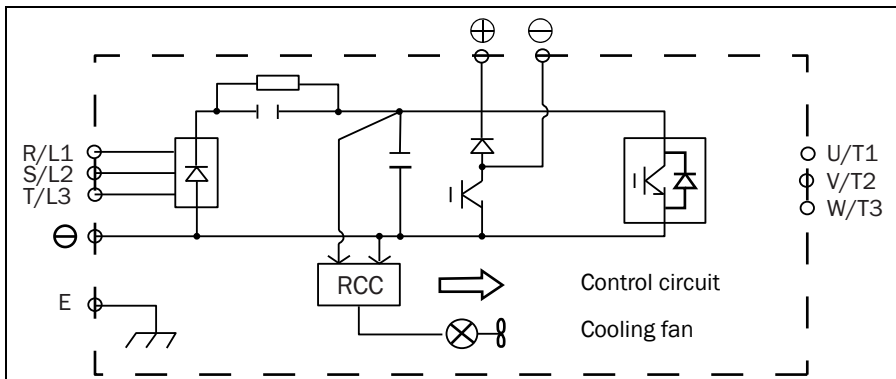

* Not used for single-phase operation

2.6 Description of VSD Terminal

Descriptions of power terminals

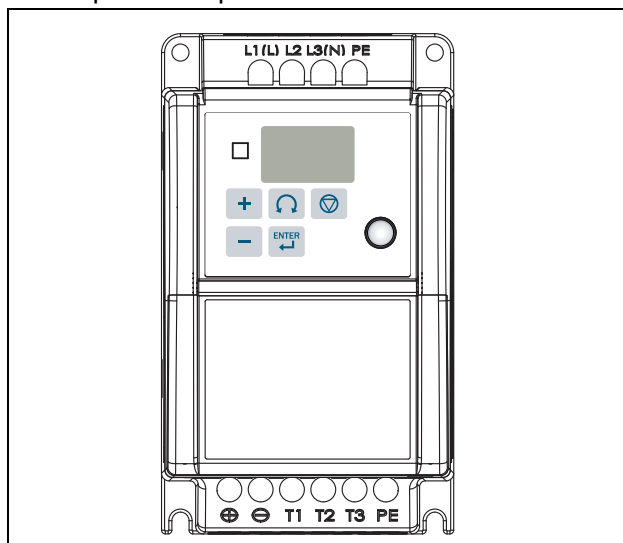

Fig. 11 Power terminals locations

Symbol	Description
L1	Main power input Single-phase: L/N* Three-phase: L1/L2/L3
L2	
L3	
⊕	DC power and braking unit connection terminals. (match with braking units and braking resistor to brake)
⊖	
T1	VSD output
T2	
T3	
PE	Grounding terminals (2 points)

* Braking units are required for applications where a load with high inertia needs to be stopped rapidly.

Use a power-matched braking unit and resistor to dissipate the energy generated by the load while stopping.

Otherwise the VSD will trip on over-voltage.

* Terminal at L2 will be non-functional for single-phase units.

Control signal terminals block description

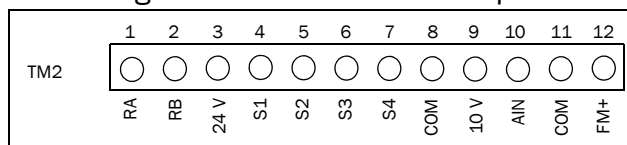

Fig. 12 Signal terminal locations

Symbol	Description	
RA	Multi-functional output terminal Normally open contact	Rated contact capacity: (250VAC/10A) Contact description: (refer to parameter [551])
RB		
10V	Supply for external potentiometer for speed reference.	
AIN	Analogue frequency signal input terminal or multi-function input terminal S7 (high level: 8V/low level: 2 V), adaptable to PNP (refer to parameter [511] description)	
24V	PNP (SOURCE) input, S1 to S4 (S5/S6/S7) common terminal, (set SW1 to PNP and connect option card power.)	
COM	NPN (SINK) input, S1 to S4 (S5/S6) common terminal, (set SW1 to NPN, and analogue input, connect option card power, output signal common terminal.)	
FM+	Multi-function analogue output + terminal (refer to parameter [531] description), output signal: DC 0-10 V.	

Symbol	Description
S1	Multi-function input terminals (refer to parameters [521] to [524] description)
S2	
S3	
S4	

SW function description

SW1	Type of external signal	Remarks
	NPN (SINK) input	
	PNP (SOURCE) input	Factory default

SW2	Type of external signal	Remarks
	0-10 VDC analogue signal	Effective when parameter [212]=2 (analogue input signal from TM1)
	0-20 mA analogue signal	

2.7 Dimension

IP20 Frame 1: Single phase: VSA23-01 to 04

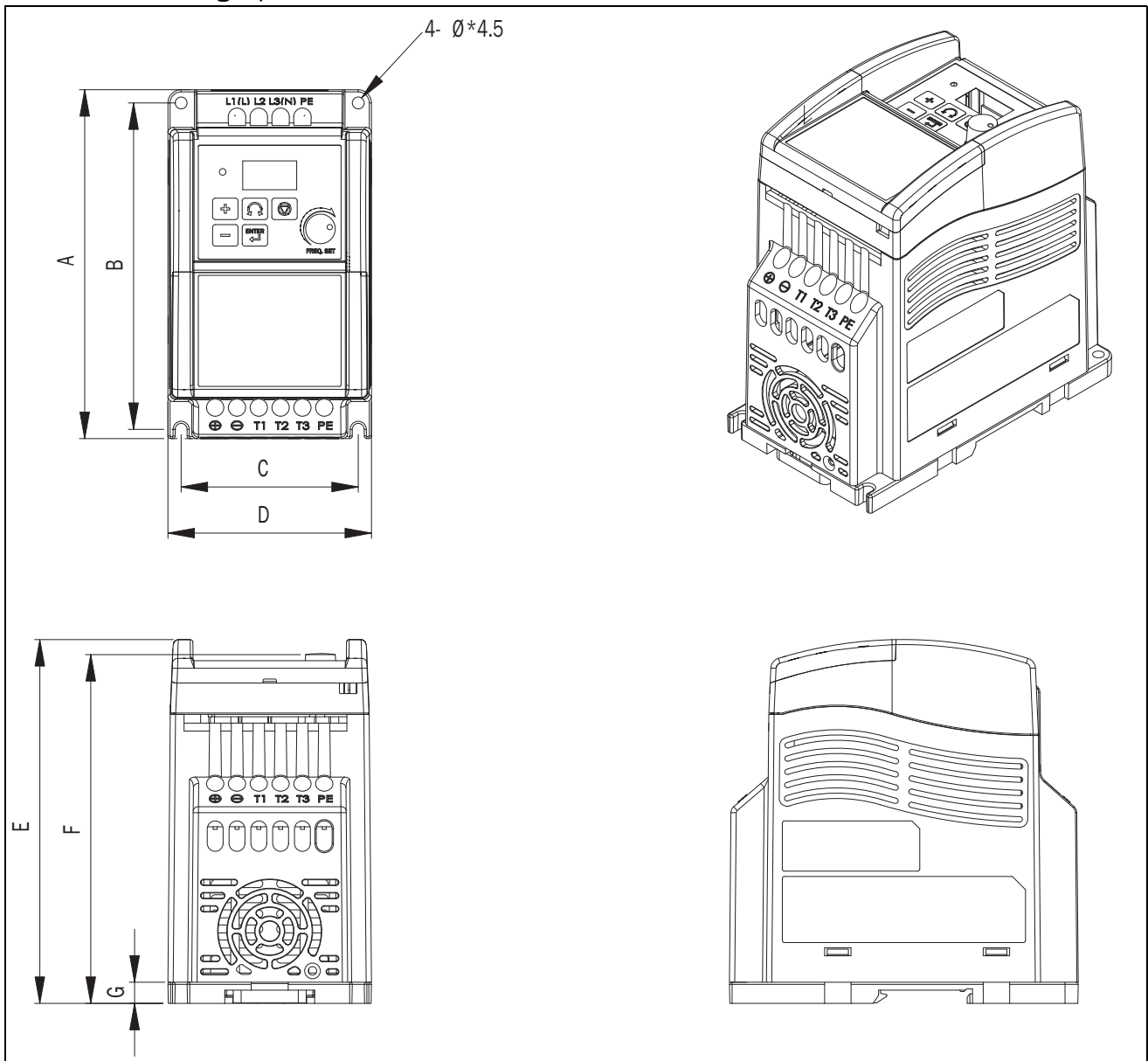

Fig. 13 VSA drive frame 1 dimensions

IP20 Frame 2: Three phase: VSA48-002 to 005

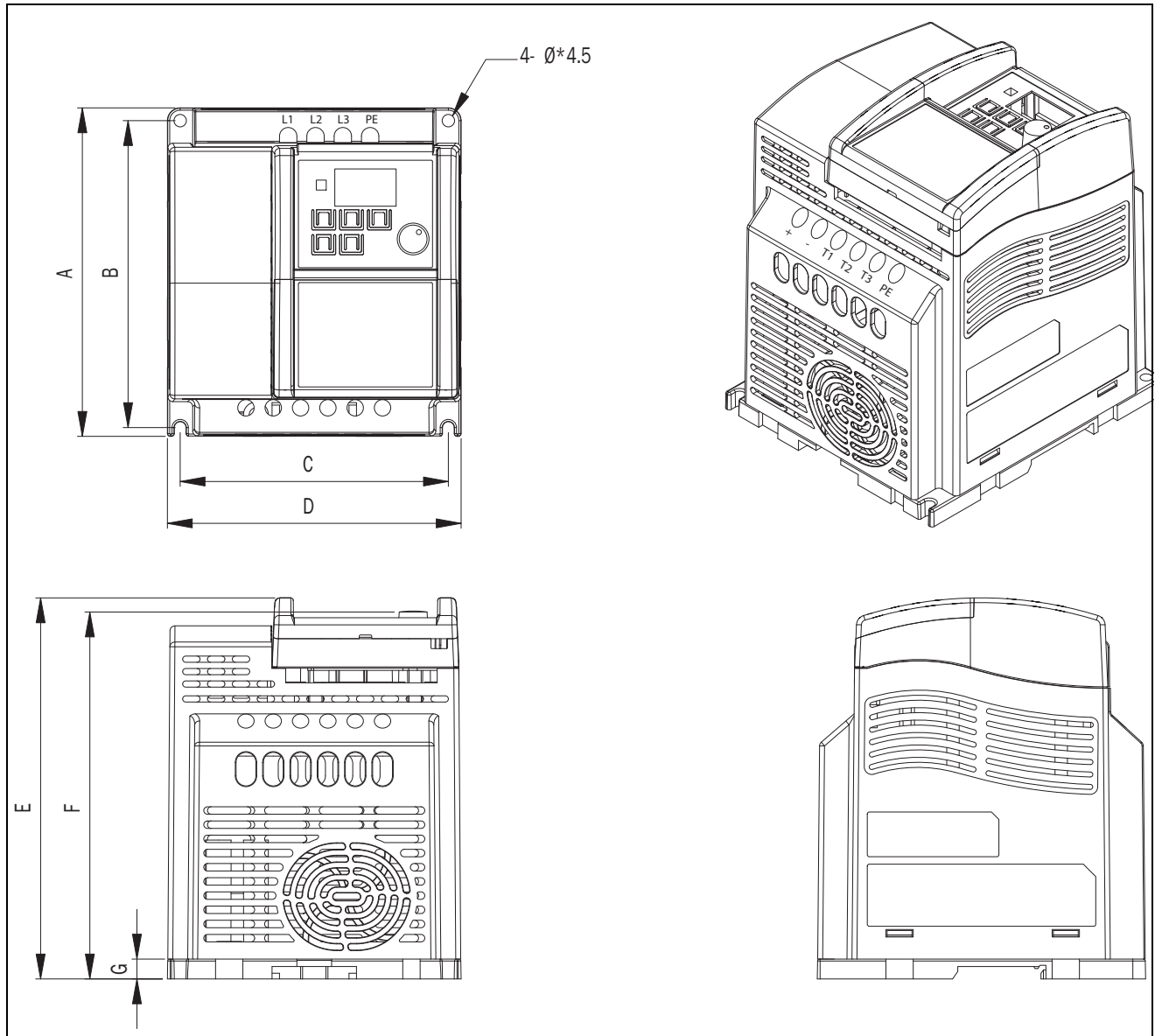

Fig. 14 VSA drive frame 2 dimensions

LENGTH MODEL	A inches/mm	B inches/mm	C inches/mm	D inches/mm
Frame 1	5.2/132	4.86/123.5	2.64/67	3.03/77
Frame 2	5.2/132	4.86/123.5	4.25/108	4.65/118
LENGTH MODEL	E inches/mm	F inches/mm	G inches/mm	
Frame 1	5.13/130.5	5.06/128.45	0.315/8	
Frame 2	5.83/148	5.67/144	0.315/8	

2.8 Installation and design consideration

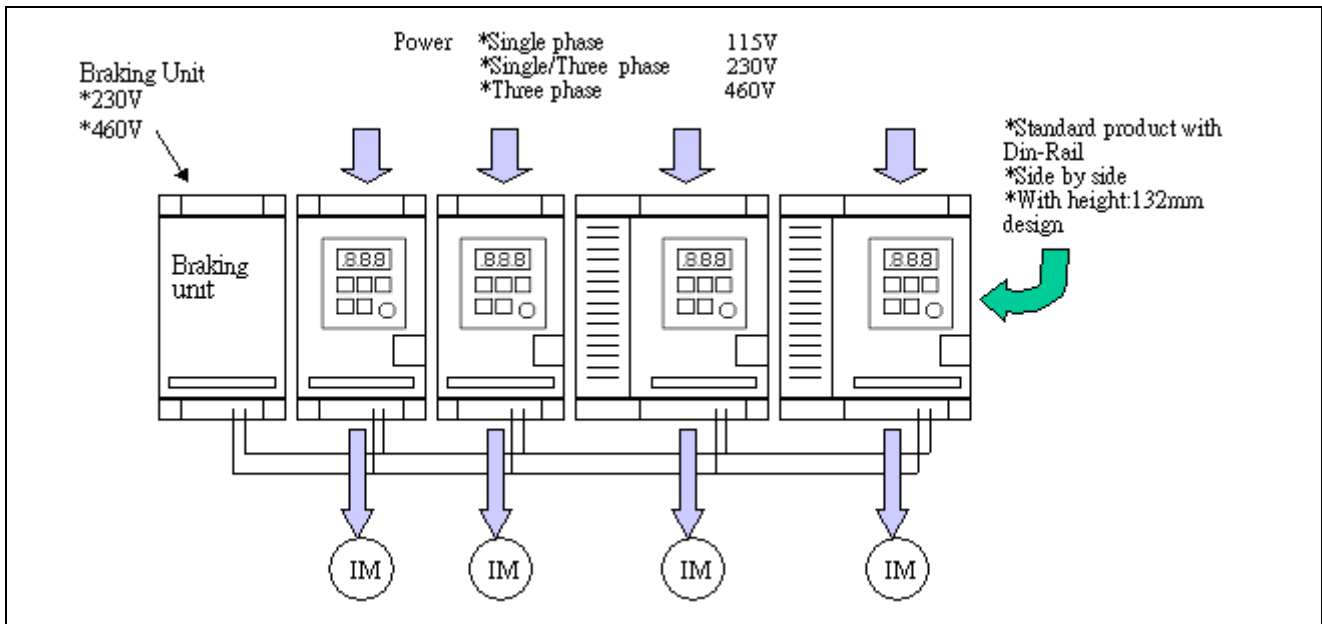
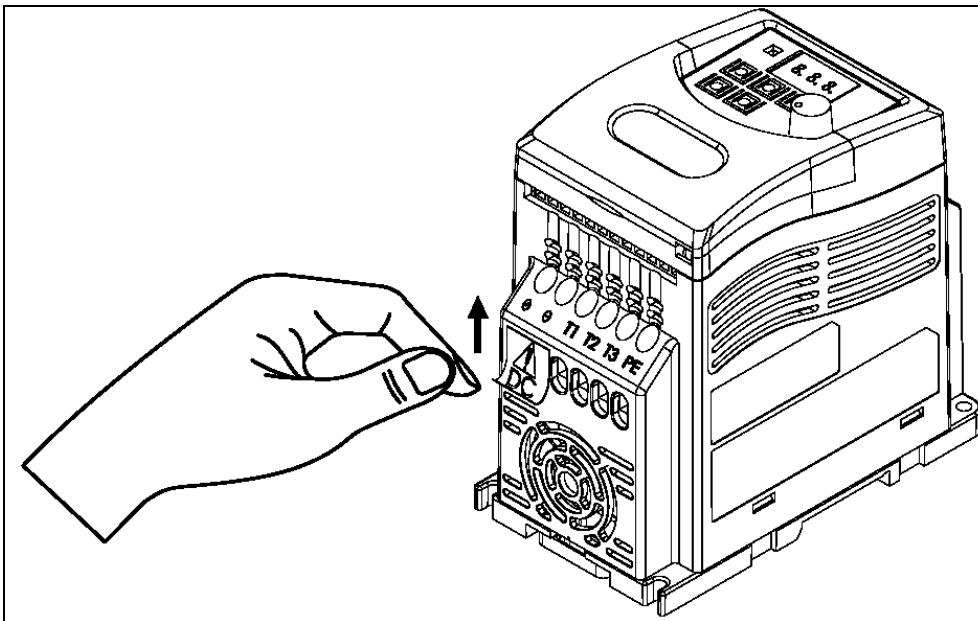

Fig. 15 Common bus configurations

NOTE 1. Common bus connections from a common input power supply as shown above.

NOTE: If + and - terminal block is used, please remove the TB label as shown below.

NOTE 2. When connecting a drive or drives' DC bus connections in parallel with larger Hp rated drives, use a magnetic contactor with the & terminals, otherwise, VSD damage can result.



3. Programming instructions and menu list

3.1 Keypad description

3.1.1 Keypad display

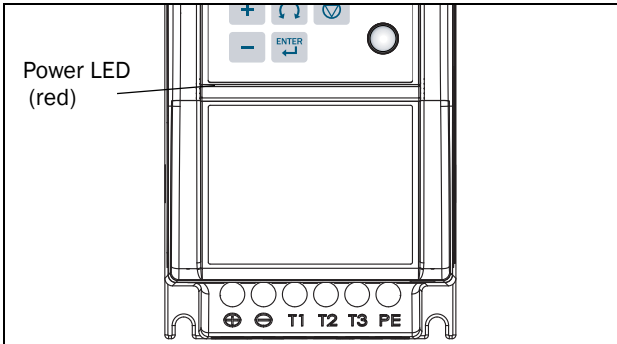

Fig. 16 Keypad layout

3.1.2 Operating Instructions for the keypad

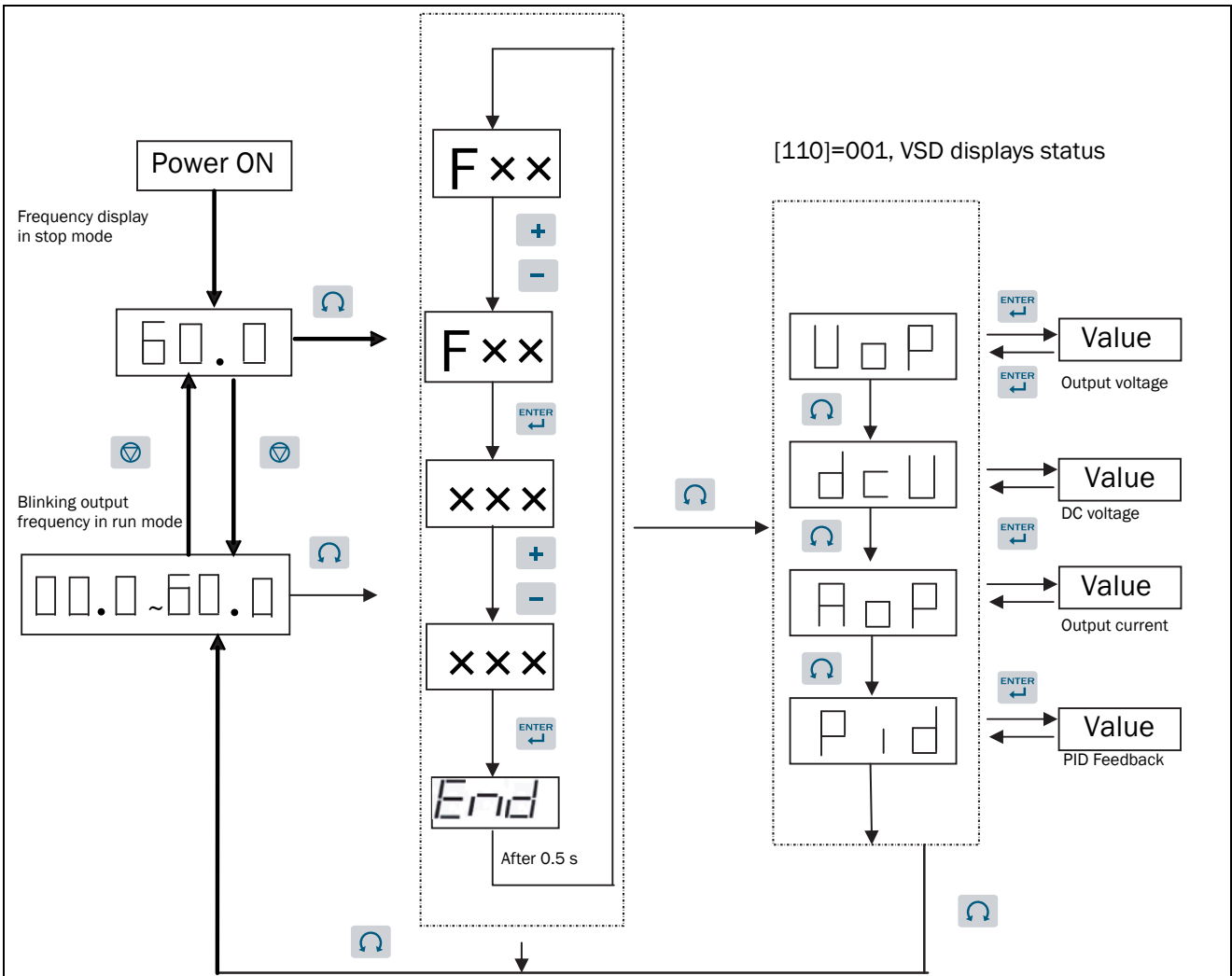

Fig. 17 Keypad Operations Sequence

*1: Display flashes with set frequency in stop mode, but it is solid in run mode.



*2: The frequency can be set during both stop and run modes.

Remote/Local change function

- Local mode

Run command via the  key on the keypad

Frequency command



When [215]=000: only the  and  key on the keypad can be used to control the output frequency and [212] setting has no effect.

When [215]=001: only VR on the keypad can control and [212] setting has no effect.

- Remote mode

Run command from menu [213] control setting

Frequency command from menu [212] control setting

Remote/Local change mode on keypad is achieved by simultaneously pressing  and . Each successive operation toggles between local and remote.

NOTE: The VSD must be stopped.





3.2 The display

Menu levels

The display has one row with space for three characters. Menu level is indicated by flashing of the corresponding character. This means:

- When you are in the first level (hundreds), the left most character is flashing.
- When you are in the second level (tens), the middle character is flashing.
- When you are in the third level (units), the right most character is flashing.

Enter data

- Press the  key to enter the editing mode.
- Use the  or  key to enter data.
- Confirm value by pressing the  key.

3.3 Menu function list

Basic menu function list

Menu	Function Description	Range/ Code	Factory Default	Remarks
Preferred view				
110	Status display parameters	000: No display 001: Display	000	*1
Main setup, Operation				
211	Control mode	000:Vector control 001:V/F Control	000	*4
212	Frequency command source	000: Up/Down key on control panel 001: Potentiometer on control panel 002: AIN input signal from (TM2) 003: Multi-function input terminal Up/Down function 004: RS-485 Communication frequency setting	000	
213	Run command source	000: keypad 001: External Terminal 002: Communication control	000	
214	Reset mode	000: RUN instruction is OFF, Reset command is available. 001: Whether RUN instruction is OFF or ON, Reset command is available.	000	
215	Local/Remote frequency control select (Run command by the Run/ Stop key)	000: Up/Down key on keypad sets frequency 001: Potentiometer on the keypad set frequency	000	
216	Reverse run instruction	000: Reverse enable 001: Reverse disable	000	
217	Fan control	000: Auto-run at set temperature 001: Run when VSD runs 002: Always run 003: Always stop	001	
218	External control operation mode	000: Forward/ Stop-Reverse/Stop 001: Run/ Stop-Forward/Reverse 002:3-wire-Run/ Stop	000	

Menu	Function Description	Range/ Code	Factory Default	Remarks
219	Remote keypad control selection	000: Disable (no signal loss detection) 001: Enable. On signal loss stop according to [337] 002: Enable. Runs at the last set frequency. On signal loss Stop is according to [213] setting or Stop key on keypad.	000	Stop VSD then connect remote keypad for proper operation *4
Main setup, Motor data				
221	Motor rated voltage			*4
222	Motor rated power			*4
223	Motor rated current			*4
224	Motor rated frequency			*4
225	Motor rated speed	0 to 120 (* 100 rpm)		*4
226	Carrier frequency	004 to 016	010	4 to 16K
Main setup, Motor protection				
231	Run stall-prevention	000: Run stall prevention available 001: Run stall prevention unavailable	000	
232	Run stall-prevention level (%)	050 to 300	200	
233	Stall prevention time during run	000: according to dec. time set in [332] 001: according to dec. time set in [239]	000	
234	Electronic thermal relay protection for motor (OL1)	000: Enable motor protection 001: Disable motor protection	000	
235	Acceleration stall-prevention	000: Acceleration stall prevention enable 001: Acceleration stall prevention disable	000	
236	Acceleration stall-prevention level (%)	050 to 200	200	
237	Deceleration stall-prevention	000: Deceleration stall prevention enable 001: Deceleration stall prevention disable	000	
238	Deceleration stall-prevention level (%)	050 to 200	200	
239	Stall prevention deceleration time set	00.1 to 999 Sec	03.0	
Main setup, Parameter set handling				
241	Copy module	000: Copy module disable 001: copy to module from VSD 002: copy to VSD from module 003: read/ write check	000	*3
242	Factory default	010: Reset to factory default (50 Hz) 020: Reset to factory default (60 Hz)	000	
Main setup, Trip Autoreset				
251	Auto-restart times	000 to 005	000	
252	Auto Restart for power-loss	000: Enable 001: Disable	001	
Main setup, Serial communication				
261	VSD communication address	001 to 254	001	*3 *4
262	Baud rate (bps)	000: 4800 001: 9600 002: 9200 003: 38400	003	*3 *4
263	Stop bit	000: 1 Stop bit 001: 2 Stop bit	000	*3 *4
264	Parity bit	000: No parity 001: Even parity 002: Odd parity	000	*3 *4

Menu	Function Description	Range/ Code	Factory Default	Remarks
265	Data bits	000: 8 bits data 001: 7 bits data	000	*3 *4
266	Communication time out detection time	00.0 to 25.5 Sec	00.0	*3
267	Communication time out operation selection	000: Deceleration to stop. ([332]: Deceleration time 1). 001: Coast to stop. 002: Deceleration to stop. ([334]: Deceleration time 2). 003: continue operating.	000	
Process and application parameters, Process settings				
321	PID OFFSET adjust (%)	000 to 109	000	*1
322	PID Error gain	0.00 to 10.0	1.00	*1
323	PID Update time (s)	00.0 to 02.5	00.0	*1
Process and application parameters, Start/stop settings				
331	Acceleration time 1	00.1 to 999s	05.0	*1 *2
332	Deceleration time 1	00.1 to 999s	05.0	*1 *2
333	Acceleration time 2	00.1 to 999 Sec	05.0	*1 *2
334	Deceleration time 2	00.1 to 999 Sec	05.0	*1 *2
335	Direct start on power up	000: Direct start available 001: Direct start disabled	001	
336	Motor rotation direction	000: Forward 001: Reverse	000	*1
337	Stopping method	000: Decelerate to stop 001: Coast to stop	000	
338	DC braking time	00.0 to 25.5 Sec	00.5	
339	DC braking start frequency	01.0 to 10.0 Hz	01.5	
33A	DC braking level	000 to 020%	005	
Process and application parameters, Speeds				
341	Frequency lower limit	00.0 to 200 Hz	00.0	*2
342	PID Sleep mode threshold	00.0 to 200 Hz	00.0	
343	PID Sleep delay time	00.0 to 25.5	00.0	
344	Frequency upper limit	01.0 to 200 Hz	50.0/60.0	*2
345	Skip frequency 1 (Hz)	00.0 to 200	00.0	*1
346	Skip frequency 2 (Hz)	00.0 to 200	00.0	*1
347	Skip frequency range (\pm Hz)	00.0 to 30.0	00.0	*1
348	Jog frequency instruction	00.0 to 200 Hz	05.0	*1
Process and application parameters, Torque				
351	Torque Boost Gain (Vector)	001 to 450		
352	Low frequency voltage compensation	000 to 40		
353	V/F Pattern setting	001 to 007	001/004	
354	Slip Compensation Gain (Vector)	001 to 450		
355	Max output frequency (Hz)	00.2 to 200	50.0/60.0	
356	Output voltage ratio at max frequency (%)	00.0 to 100	100	
357	Mid frequency (Hz)	00.1 to 200	25.0/30.0	
358	Output voltage ratio at mid frequency (%)	00.0 to 100	50.0	
359	Min output frequency (Hz)	00.1 to 200	00.5/00.6	
35A	Output voltage ratio at Min frequency (%)	00.0 to 100	01.0	
35B	Torque boost gain (V/F)	00.0 to 30.0%	00.0	*1
35C	Slip Compensation Gain (V/F)	00.0 to 100%	00.0	*1

Menu	Function Description	Range/ Code	Factory Default	Remarks
Process and application parameters, Preset references				
361	Frequency Up/ Down control using MFIT	000: Up/Down command is available. Set frequency is held when VSD stops. 001: Up/Down command is available. Set frequency resets to 0Hz when VSD stops. 002: Up/Down command is available. Set frequency is held when VSD stops. Up/Down is available in stop.	000	
362	Preset frequency 1 (Main frequency setting)	00.0 to 200 Hz	05.0	*1
363	Preset frequency 2	00.0 to 200 Hz	05.0	*1
364	Preset frequency 3	00.0 to 200 Hz	10.0	*1
365	Preset frequency 4	00.0 to 200 Hz	20.0	*1
366	Preset frequency 5	00.0 to 200 Hz	30.0	*1
367	Preset frequency 6	00.0 to 200 Hz	40.0	*1
368	Preset frequency 7	00.0 to 200 Hz	50.0	*1
369	Preset frequency 8	00.0 to 200 Hz	60.0	*1
Process and application parameters, PID Process control				
381	PID operation mode	000: PID Function unavailable 001: PID control, Bias D control 002: PID Control, Feedback D control 003: PID Control, Bias D reverse characteristics control. 004: PID Control, feedback D reverse characteristics control.	000	
382	PID OFFSET	000: Positive direction 001: Negative direction	000	*1
383	P: Proportional gain	0.00 to 10.0	01.0	*1
384	I: Integral time (s)	00.0 to 100	10.0	*1
385	D: Differential time (s)	0.00 to 10.0	0.00	*1
Load monitor				
411	Alarm Select	000: Off 001: Min 002: Max 003: Min+Max	000	*1
412	Alarm Trip	000: Off 001: Min 002: Max 003: Min+Max	000	*1
413	Ramp Alarm	000: Off 001: On	000	*1
414	Alarm Start Delay	0 to 999 s	002	*1
415	Load Type	000: Basic 001: Load Curve	000	*1
416	Max Alarm Margin	0 to 400%	015	*1
417	Max Alarm Delay	0 to 90 s	01.0	*1
418	Max Pre-Alarm Margin	0 to 400%	010	*1
419	Max Pre-Alarm Delay	0 to 90 s	01.0	*1
41A	Min Pre-Alarm Margin	0 to 400%	010	*1
41B	Min Pre-Alarm Delay	0 to 90 s	01.0	*1
41C	Min Alarm Margin	0 to 400%	010	*1
41D	Min Alarm Delay	0 to 90 s	01.0	*1
41E	AutoSet Alarm	000: No 001: Yes	000	*1
41F	Normal Load	0 to 400% of max torque	100	*1

Menu	Function Description	Range/ Code	Factory Default	Remarks
Load monitor, Load curve				
421	Load Curve 1	0 to 400% of max torque	100	*1
422	Load Curve 2	0 to 400% of max torque	100	*1
423	Load Curve 3	0 to 400% of max torque	100	*1
424	Load Curve 4	0 to 400% of max torque	100	*1
425	Load Curve 5	0 to 400% of max torque	100	*1
426	Load Curve 6	0 to 400% of max torque	100	*1
427	Load Curve 7	0 to 400% of max torque	100	*1
428	Load Curve 8	0 to 400% of max torque	100	*1
429	Load Curve 9	0 to 400% of max torque	100	*1
Process protection				
432	Motor no load current			Varies with motor rating *4
433	V/F base output voltage set	198 to 265 V/380 to 530 V	220/440	
I/O's, Analogue inputs				
511	Terminal AIN function	000: Forward 001: Reverse 002: Preset Speed Command 1 003: Preset Speed Command 2 004: Preset Speed Command 3 005: Jog frequency Command 006: Emergency stop(E.S.) 007: Base Block (b.b.) 008: Select 2nd acc/dec time 009: Reset 010: Up command 011: Down command 012: Control signal switch 013: Communication control signal switch 014: Acceleration/deceleration prohibit 015: Master/Auxiliary speed source select 016: PID function disable 017: Analog frequency signal input (terminal AIN) 018: PID feedback signal (terminal AIN) 019: DC Brake signal	017	
512	AIN signal select	000: 0–10V (0–20mA) 001: 4–20mA (2–10V)	000	
513	Confirming AIN signal scan time (ms x 8)	001 to 100	050	
514	AIN Gain (%)	000 to 200	100	*1
515	AIN Bias (%)	000 to 100	000	*1
516	AIN Bias	000: Positive 001: Negative	000	*1
517	AIN slope direction	000: Positive 001: Negative	000	*1
518	Multi-function input terminal S1 to S6 signal scan time (ms x8)	001 to 100	010	

Menu	Function Description	Range/ Code	Factory Default	Remarks
I/O's, Digital inputs				
521	Terminal S1 function	000: Forward 001: Reverse	000	
522	Terminal S2 function	002: Preset Speed Command 1 003: Preset Speed Command 2 004: Preset Speed Command 3 005: Jog frequency Command	001	
523	Terminal S3 function	006: Emergency stop(E.S.) 007: Base Block (b.b.) 008: Select 2nd acc/dec time	005	
524	Terminal S4 function	009: Reset 010: Up command 011: Down command	006	
525	Terminal S5 function (option)	012: Control signal switch 013: Communication control signal switch 014: Acceleration/deceleration prohibit	007	
526	Terminal S6 function (option)	015: Master/Auxiliary speed source select 016: PID function disable 019: DC Brake signal 020: Enable	009	
I/O's, Analogue outputs				
531	Multi-function output analogue type selection (0–10 VDC)	000: Output frequency 001: Set frequency 002: Output voltage 003: DC voltage 004: Output current 005: PID feedback signal	000	*1
532	Multi-function analogue output gain (%)	000 to 200%	100	*1
I/O's, Digital outputs				
541	Multi-function output T+, T- (option)	000: Run 001: Frequency reached (Set frequency \pm [612]) 002: Frequency is within the range set by ([611] \pm [612]) 003: Frequency detection (>[611]) 004: Frequency detection (<[611]) 005: Fault terminal 006: Auto-restart 007: Momentary power loss 008: Emergency Stop (E.S.) 009: Base Block (b.b.) 010: Motor overload protection 011: VSD overload protection 012: Reserved 013: Power ON 014: Communication error 015: Output current detection(>[613]) 016: No Fault	005	

Menu	Function Description	Range/ Code	Factory Default	Remarks
I/O's, Relays				
551	Multi-function output RY1	000: Run 001: Frequency reached (Set frequency \pm [612]) 002: Frequency is within the range set by ([611] \pm [612]) 003: Frequency Detection (>[611]) 004: Frequency Detection (<[611]) 005: Fault terminal 006: Auto reset and restart 007: Momentary power loss 008: Emergency Stop (E.S.) 009: Base Block (b.b.) 010: Motor overload protection 011: VSD overload protection 012: Reserved 013: Power On 014: Communication error 015: Output current detection(>[613]) 016: No Fault	000	
Logical functions, Comparators				
611	Output frequency at the Set value (Hz)	00.0 to 200	00.0	*1
612	Frequency detection range (\pm Hz)	00.0 to 30.0	00.0	*1
613	Output current set value	000 to 100%	000	
614	Output current detection time	00.0 to 25.5 (Sec)	00.0	
View trip log, Trip message				
811	Latest 3 fault records			*3 *4
System data, VSD data				
921	VSD horse power capacity			
922	Software version			*3 *4

NOTE:

- *1: Can be modified in Run mode.
- *2: Frequency resolution is 1 Hz for settings above 100 Hz.
- *3: Cannot be modified during communication.
- *4: Do not change while making factory setting.

3.4 Menu function description

Basic function menu list

110 Status monitoring display
000: Disable
001: Enable.

[110]=001 displays motor current, voltage, DC bus voltage, and PID feedback.

Menu [213]=000 must be set to 000 for this function to be effective.

211 Control mode
000: Vector control
001: V/F control.

212 Frequency signal source
000: Up/Down key on keypad
001: Potentiometer on keypad
002: TM2 input signal (terminal AIN)
003: Multi-function input terminal Up/Down function
004: Frequency set by communication method (When [219]=1, Remote Keypad has priority)

1. [212]=001, when any of parameter group [521] to [524] is set to 015 and multi-function input terminal is OFF, the frequency is set by the potentiometer on the keypad. If the multi-function input terminal is ON, the frequency is set by the analogue signal (auxiliary speed) from TM2.
2. [212]=002, when any of menu [521] to [524] is set to 015 and multi-function input terminal is OFF, the frequency is set by the analogue signal (auxiliary speed)

from TM2. If the multi-function input terminal ON, the frequency is set by the potentiometer on Keypad.

3. Up/Down terminal: please refer to description of menu [521] to [524] (multi-function input terminal).
4. Priority of reading frequency command: Jog> preset frequency > (Keypad or TM2 Up/ Down or communication).

213 Run signal source

000: Keypad
001: External Terminal
002: Communication Control

1. [213]=000, VSD is controlled by keypad.
2. [213]=001, VSD is controlled by external terminal.
3. [213]=002, VSD is controlled by serial communication.

214 Reset mode

000: Reset is enable when RUN switch is OFF.
001: Reset is enable with RUN switch OFF or ON.

[214]=000. Fault can not be reset, therefore the VSD can not start when the RUN switch is in ON position. ([213]=001).

215 Local /Remote control select description

- Local mode

Run command

The Run/Stop pad on the keypad controls VSD [213] setting has no effect on control.

Frequency command



When [215]=000: the Up/Down key controls the drive and the [212] setting has no effect.

When [215]=001: the potentiometer on the keypad controls frequency, and [212] setting has no effect.

- Remote mode

Run command is by the run menu [213] setting.

Frequency command from the frequency menu [212] setting

- Control select mode is changed by simultaneously pressing the  and  keys (The drive must be in stop mode).

216 Reverse run

000: Reverse enable
001: Reverse disable

When [213]=000 and [216]=001, [336] (motor direction) is disabled, the VSD is set to forward operation.

When [213]=001 or 002, and [216]=001, reverse command is disabled.

217 Fan control

000: Auto-run by temperature
001: Run when VSD running
002: Always run.
003: Always stop.

1. [217]=000: The fan will auto run at or above a set certain temperature in order to extend the life span of the fan.
2. [217]=001: The fan runs as long as VSD is running.
3. [217]=002: The fan runs as long as power is supplied.
4. [217]=003: The fan does not run at any time.

218: External control operation mode

000: Forward/ Stop-Reverse/Stop
001: Run/ Stop-Forward/Reverse
002: 3-wire-Run/ Stop

1. [218] is only available when [213]=001 (external terminal).
2. When both forward and reverse commands are ON, this will result in a stopped mode.

Menu [218]=000, control method is as follows:

(1) Input signal is NPN

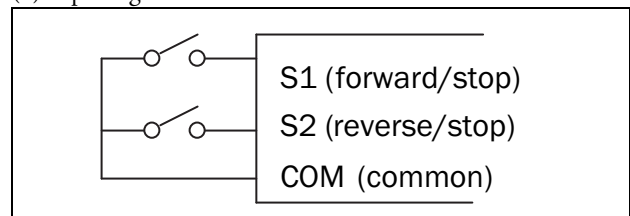

(2) Input signal is PNP

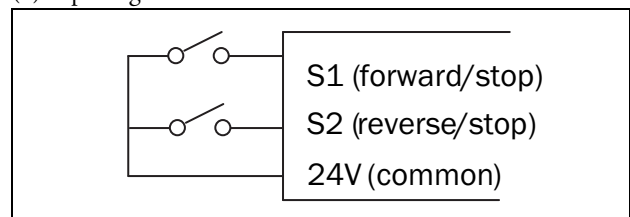
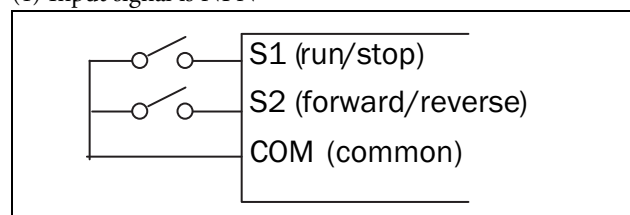

Fig. 18 Fwd/stop-Reverse/Stop wiring detail

Menu [218]=001, control method is as follows:

(1) Input signal is NPN



(2) Input signal is PNP

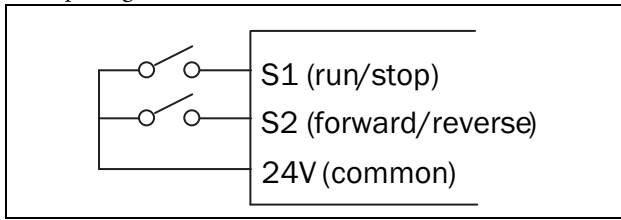
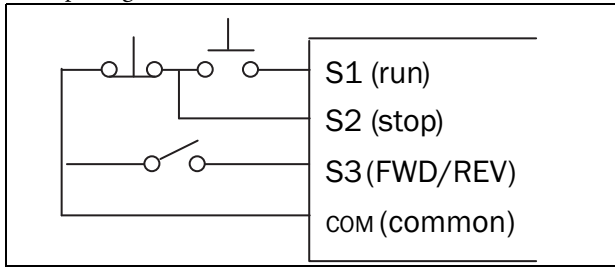

Fig. 19 RUN/STOP-Forward/Reverse Wiring detail

Menu [218]=002, control method is as follows:

(1) Input signal is NPN



(2) Input signal is PNP

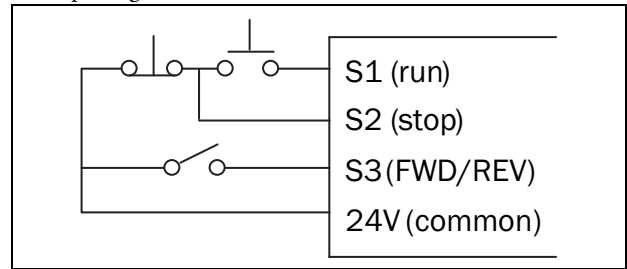

Fig. 20 3-WIRE Run/Stop detail

NOTE: In 3-wire control mode terminals S1-S3 are used, therefore menus [521] to [523] are ineffective.

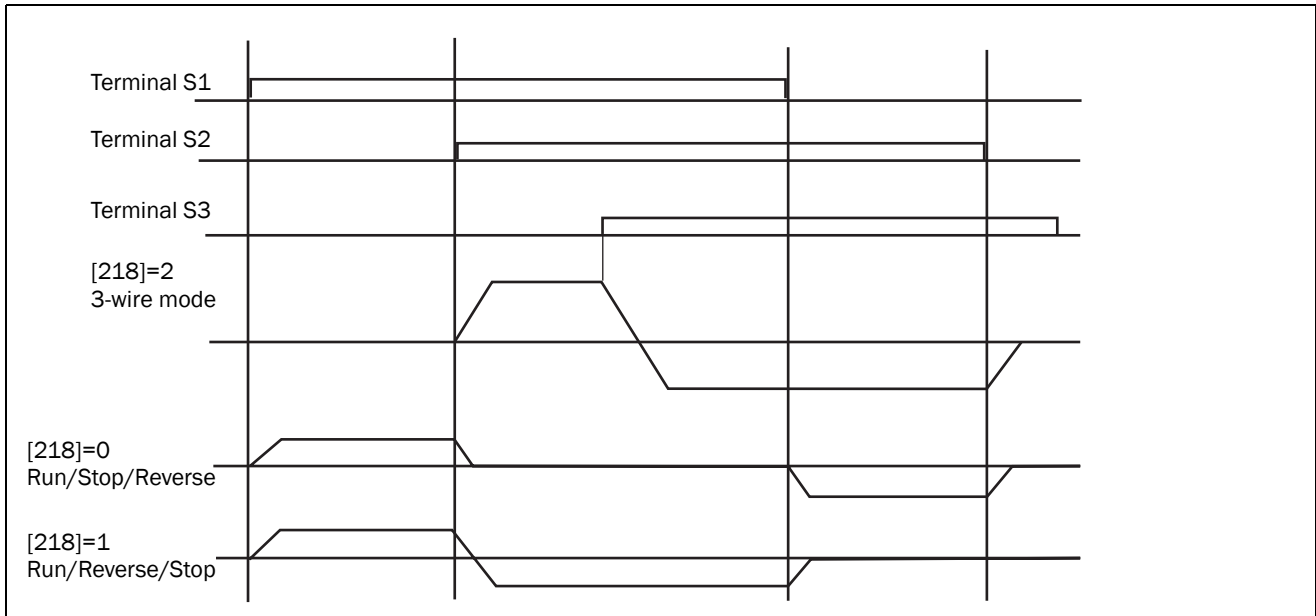

Fig. 21 Control Method Sequences :

Stop bytes: 1 bit

NOTE: [216]=001, reverse command is disabled.

NOTE: 1. Connect remote keypad while in stop mode, and the control priority is with the Remote keypad.

219 Remote keypad control selection
 000: Disable
 001: Enable. Operation according to [337] on signal loss.
 002: Enable. Operation at the last set frequency on signal loss.
 (Stop mode by VSD keypad or menu [213] as appropriate).

2. If the remote keypad is connected in run mode, it will not be effective until the VSD has stopped.

When [219]=001, [261] to [265] set parameter disable the following menus will be auto set:

VSD communication address: No 1 data bytes: 8 bit
 Baud rated (bps): 38400 parity bytes: no parity

221 Motor rated voltage (VAC)
 222 Motor rated power (KW)
 223 Motor rated current (A)
 224 Motor rated frequency (Hz)
 225 Motor rated speed (RPM): 225 x 10= Motor rated speed

226 Carrier frequency (kHz): 004-016
 Set this menu to a level from 4-16 kHz as required. (Default is 10 kHz).

- To reduce noise due to long cable decrease carrier frequency.
- To reduce motor audible noise increase carrier frequency. However the output current from the VSD will be derated according to the table on page 33.

***NOTE: In situations where there is excessive audible noise from the motor or it is required to reduce electrical noise from the VSD caused by use of long cable then the carrier frequency can be adjusted as follows:**

226	Carrier frequency	226	Carrier frequency	226	Carrier frequency	226	Carrier frequency
004	4KHz	008	8KHz	012	12KHz	016	16KHz
005	5KHz	009	9KHz	013	13KHz		
006	6KHz	010	10KHz	014	14KHz		
007	7KHz	011	11KHz	015	15KHz		

Corresponding list of current and carrier frequency

Model Carrier frequency	VSA23-01	VSA23-03	VSA23-04	VSA23-07	VSA23-10	VSA48-002	VSA48-004	VSA48-005
4 to 10K	1.7	3.1	4.2	7.5	10.5	2.3	3.8	5.2
12K	1.7	3.1	4.2	7.5	10.5	2.2	2.2	3.7
	1.6	3.0	4.0	7.0	10.0	2.2	2.2	3.6
16K	1.5	2.8	3.8	6.8	8.7	2.1	2.1	3.5

231 Run stall-prevention:

000: Enable Stall prevention in Run mode.
001: Disable Stall prevention in Run mode.

232 Run stall-prevention level: 050% to 200%

233 Stall prevention time during run mode.

000: Set in menu [332] (Deceleration 1).
001: Set in menu [239].

234 Electronic thermistor protection for motor (OL1):

000: Protection Enabled
001: Protection Disabled

235 Acceleration stall-prevention:

000: Enable Stall prevention during Acceleration.
001: Disable Stall prevention during Acceleration.

236 Acceleration stall-prevention level: 050% to 200%

237 Deceleration stall-prevention:

000: Enable Stall prevention during deceleration.
001: Disable Stall prevention during deceleration.

238 Deceleration stall-prevention level: 050% to 200%

239 Stall prevention deceleration time: 00.1 to 999 s.

- When the acceleration time is set too low, the VSD could trip on Over Current (OC).
If the time can not be increased then trip prevention can be used. A trip prevention level has to be programmed. When the VSD detects this level it holds the acceleration until the current is below this set level and then continues with acceleration.
- When the deceleration time is set too low the VSD could trip on Over-voltage (OV).
If the time can not be increased then trip prevention can be used. A trip prevention level has to be programmed. When the VSD detects this level it holds the deceleration until the voltage is below this set level and then continues with deceleration.

The VSD could trip (Stall) during run mode due to an impact load or sudden change of the load. Stall prevention in run mode will detect a programmed stall level [232] for a period of time [233]. If the level exceeds

[232], then the VSD reduces its frequency (speed) to provide the required additional torque to overcome the stall. Once this level is below the programmed stall level, then it will ramp up to its normal running speed.

241 Copy module

000: Copy module disable
001: Copy to module from VSD
002: Copy to VSD from module
003: Read/write check

242 Factory default

010: Reset to factory default (50Hz)
020: Reset to factory default (60Hz)

251 Auto restart times: 000 to 005

- [251]=000: The VSD will not auto-restart on fault trip.
- [251]>000
The VSD will carry out an auto search 0.5 sec after the fault trip while the VSD output is switched off and the motor is coasting to stop.
Once the rotation speed is determined the VSD will accelerate or decelerate to the speed it had before the fault occurred.
- Auto restart is not available for OL1, OL2, OH, BB, faults.

NOTE: Auto restart will not work while DC injection braking or deceleration to stop is performed.

252 Auto restart on momentary power loss.

000: Enable
001: Disable

[252]=000: Auto restart after a momentary power loss is enabled on resumption of power and applying the run signal, according to setting of menu [213].

The VSD will carry out an auto speed search, once the motor rotation speed is found then it will accelerate to the running speed it had before the power loss.

[252]=001: Disable

261 VSD communication address: 001 to 254

[261] set communication address, for the specific VSD when multi-VSDs are controlled by communication method.

262 Baud rate (bps)
000: 4800
001: 9600
002: 19200
003: 38400

263 Stop bit
000: 1 Stop bit
001: 2 Stop bit

264 Parity bit
000: No parity
001: Even parity
002: Odd parity

265 Data bits
000: 8 bits data
001: 7 bits data

1. RS-485 communication: (requires RS485 port device)

1 to 1 control: PC or PLC or controller controls one VSD ([261] is set to 001 to 254).

1 to multiple drives control: PC or PLC or other controllers control several VSDs (the maximum number of units which can be controlled is 32). When the communication address =000, the VSD is controlled by communication regardless of the [261] setting.

2. RS-232communication: (requires RS232 port)

1 to 1 control: PC or PLC or controller controls one VSD ([261] is set to 001 to 254).

NOTE: a. The Baud rate [262] and communication format ([263]/[264]/[265]) of the PC (or PLC or other controller) and VSD should be the same.

b. The VSD will validate the modified parameters after the parameters modified in the PC.

c. Communication protocol: refer to EV communication protocol description.

d. Parameter [261] to [265] can't be changed via communication module

266 Communication Time out detection time

Time-out detection time: 00.0 to 25.5sec; setting 00.0 sec: disable time-out function.

Default: 00.0 sec

Communication time-out detection is independent of RUN/Frequency command.

*Cannot be modified during communication.

267 Communication Time out operation selection

Time-out operation selection:

000: Deceleration to stop ([332]: Deceleration time 1).

001: Free run to stop.

002: Deceleration to stop ([334]: Deceleration time 2).

003: Continue operating.

Default=000

Reset method:

a. Use the Reset key

b. Receive correct data from the master.

NOTE: After communication time-out the motor decelerates to stop ([267]=000,001,002). The motor will not start unless a new RUN command is given according to [213].

*Cannot be modified during communication.

[266]/[267] Communication time out parameter timing pattern.

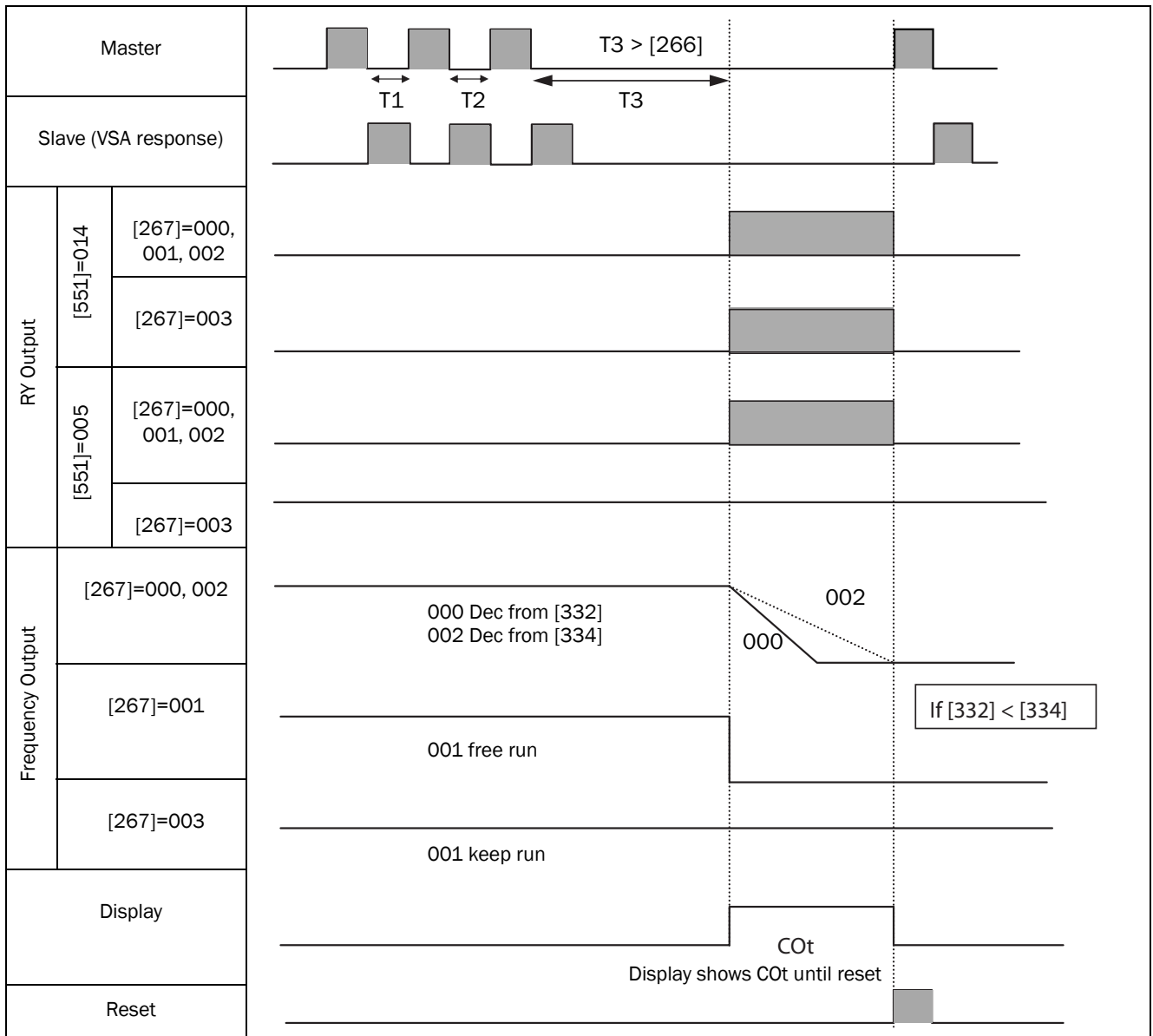

Fig. 22 Communication error timing pattern

321 PID offset adjust (%): 000 to 109%

PID operation result can be adjusted by [321] ([382] effects the polarity of [321]).

[322] is PID error gain, that is feedback value = feedback value × [322].

322 PID error gain: 0.00-10.0

323 PID update time (s): 00.0-02.5

[323]: The refresh time of the PID output command.

NOTE: PID function is used in flow control, external fan wind volume control, and temperature control.

See flow control diagram below.

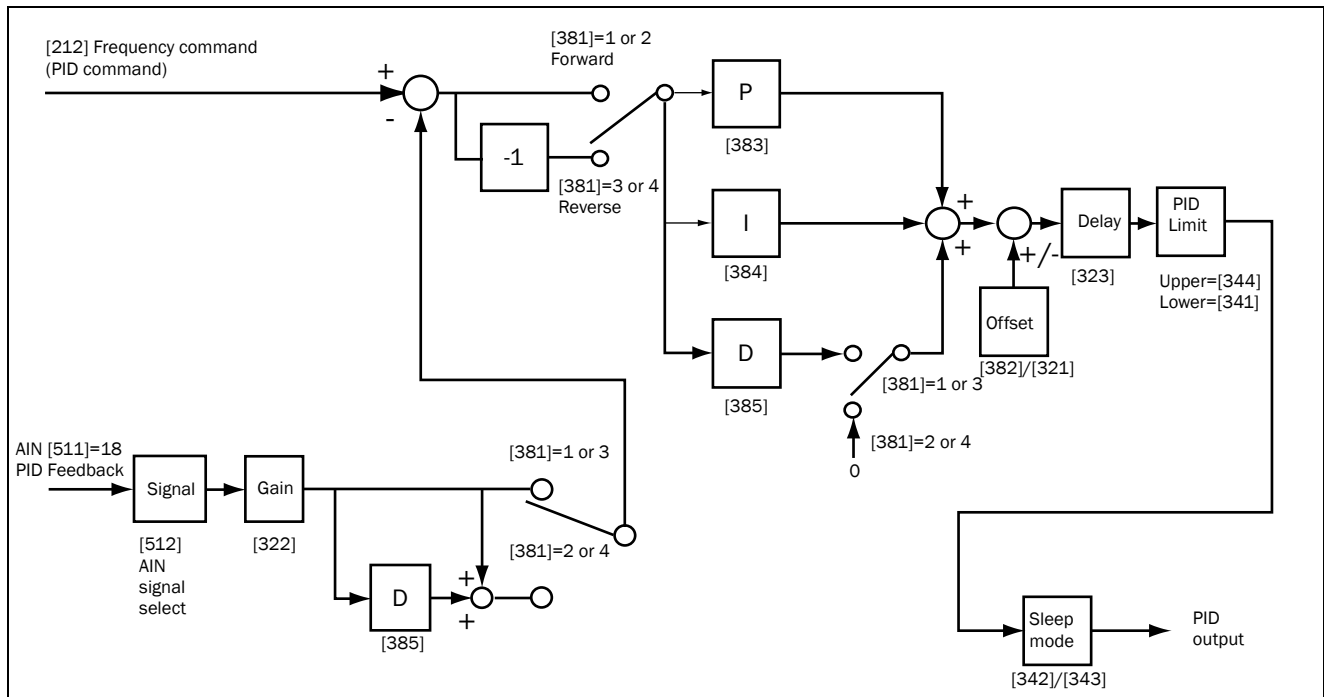

Fig. 23 PID flow control diagram

1. In PID mode select, AIN on TM2 is the PID feedback signal (Set [511]=018.)
2. The PID command (set point) is selected in menu [212] (selections 000 and 001).

This value is stored in [362].

331 Acceleration time 1 (s): 00.1 to 999
332 Deceleration time 1 (s): 00.1 to 999

333 2nd acceleration time (s): 00.1 to 999
334 2nd deceleration time (s): 00.1 to 999

Formula for acceleration/deceleration time: Denominator is based on the setting of [211].

- a) Motor rating frequency (Sensor less vector control [211]=000).
- b) Max output frequency (V/F mode [211]=001)
a (vector)

$$\text{Acceleration time} = [331] \times \frac{\text{Set frequency}}{[224] \text{ (rated frequency)}}$$

$$\text{Deceleration time} = [332] \times \frac{\text{Set frequency}}{[224] \text{ (rated frequency)}}$$

b (V/F)

$$\text{Acceleration time} = [331] \times \frac{\text{Set frequency}}{[355] \text{ (Max output frequency)}}$$

$$\text{Deceleration time} = [332] \times \frac{\text{Set frequency}}{[355] \text{ (Max output frequency)}}$$

335 Direct start on power up
000: Enable direct start on power up.
001: Disable direct start on power up.



Danger: 1. When [335]=000 and external run mode ([213]=001), the VSD will auto start when the power is supplied to the VSD and the run switch is ON.

This feature should only be considered when all safety implications of its use have been investigated. (Risk assessment for maintenance, use of warning labels etc.)

We recommend that this mode stay disabled.

3. When [335]=001 and external run mode ([213]=001), the VSD will not auto start when power is supplied and the RUN switch is ON.
The display will blink "SP1" error message. It can only

restart after the RUN switch was turned off and ON again.

336 Motor rotation direction
 000: Forward
 001: Reverse

337 Stopping method
 000: Decelerate to stop
 001: Free run (Coast) to stop

1. [337]=000: after receiving stop command, the motor will decelerate to stop according to setting of [332], deceleration time 1.
2. [337]=001: after receiving stop command, the motor will free-run (Coast) to stop.

338 DC braking time (s): 00.0 to 25.5
 339 DC braking start frequency (Hz): 01.0 to 10.0
 33A DC braking level (%): 00.0 to 20.0%

[338]/[339]: DC braking time and start frequency, per the following figure:

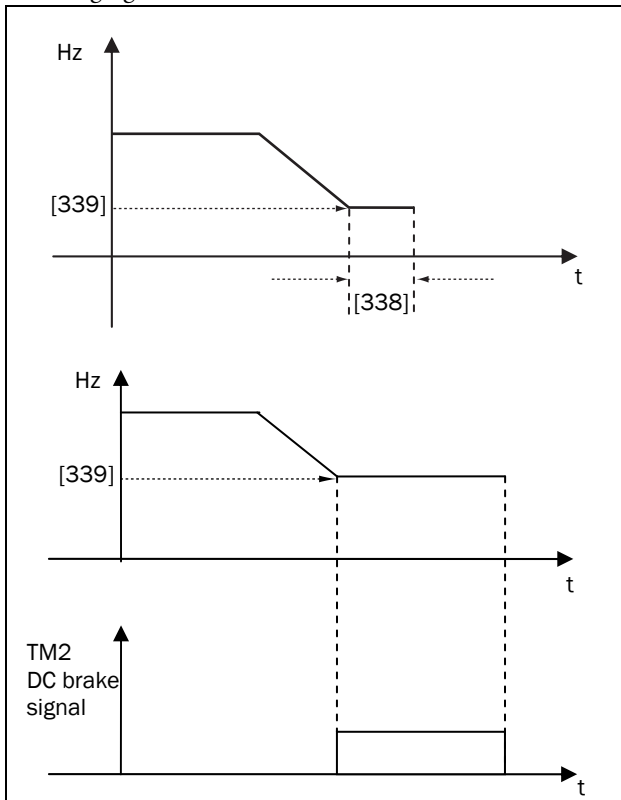

Fig. 24 DC Injection Braking

341 Frequency lower limit (Hz): 00.0 - 200
 342 PID Sleep start frequency (Hz) 00.0 to 200 Hz
 343 PID Sleep delay time (sec) 00.0 to 25.5 sec
 344 Frequency upper limit (Hz): 01.0 - 200

PID sleep mode requires setting all functions below

- [381]=001 to 004(PID Enable)
- [511]=018(AIN is PID feedback signal)
- [362]=PID preset frequency
- [342] sleep start frequency, unit: Hz
- [343] PID sleep delay time, unit: Sec

When PID output frequency becomes lower than the PID sleep start frequency [342] for a period of time [343], then the VSD output will decelerate to zero speed (Sleep mode). When the PID output frequency becomes higher than the sleep start frequency [342], the VSD output accelerates to PID output frequency (Wake mode). Refer to Fig. 26.

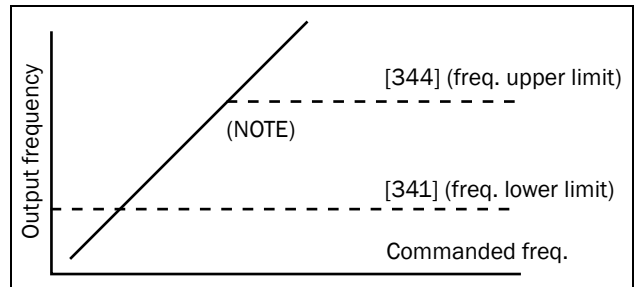

Fig. 25 Frequency Limits

NOTE: If [344]=0 Hz and frequency command = 0 Hz, the VSD will 0-speed stop.

If [341] > 0 Hz and frequency command [341], VSD will run at [341] set value.

345 Skip frequency 1 (Hz): 00.0 to 200
 346 Skip frequency 2 (Hz): 00.0 to 200
 347 Skip frequency range (\pm Hz): 00.0 to 30.0

Example: [345]=10.0 Hz/[346]=20.0 Hz/[347]=02.0 Hz

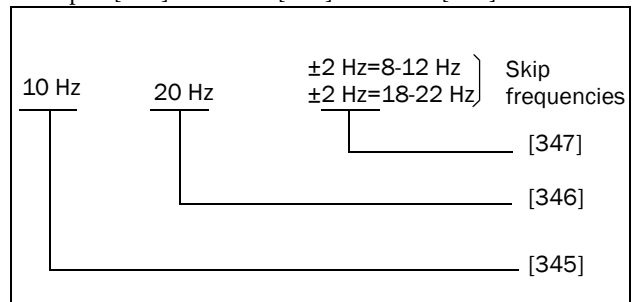

Timing diagram is as following:

348 Jog frequency (Hz): 00.0 to 200

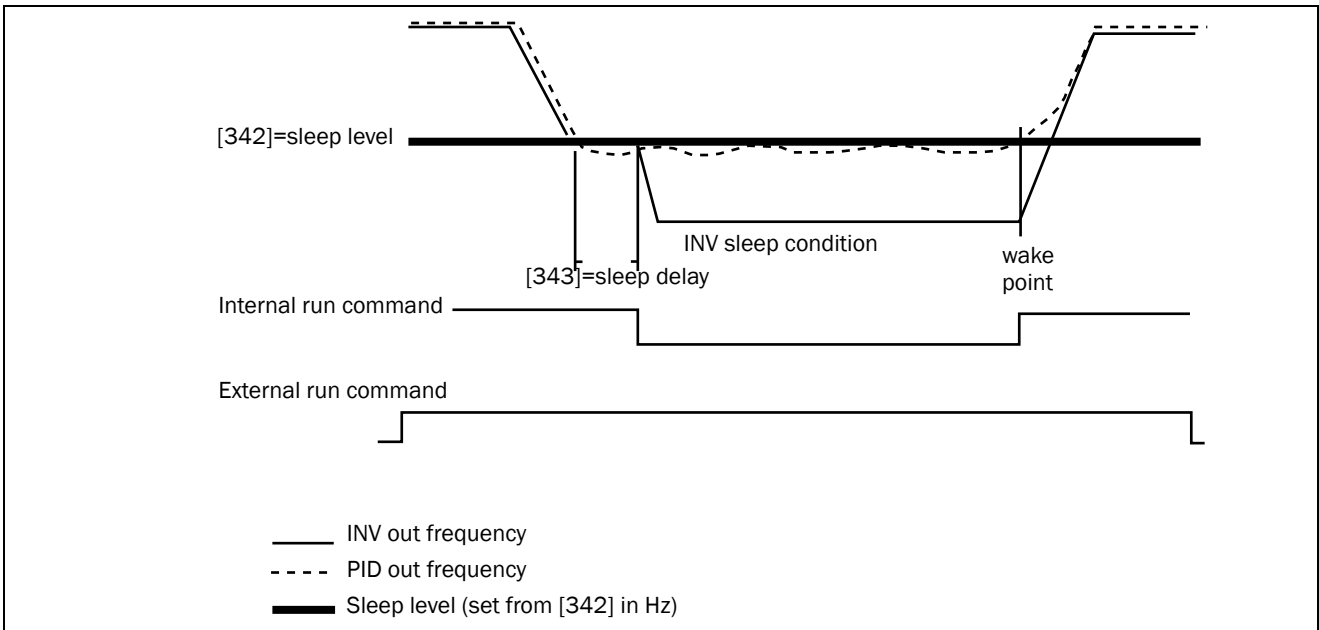

Fig. 26 Sleep/ Wake Mode

351 Torque boost gain (Vector), [211]=000

Performance: If the motor load is determined to be too large increase the output torque.

$$\Delta T_e = I \times \text{Gain}$$

I=load current

Gain= compensation gain

- Torque/Speed curve pattern:

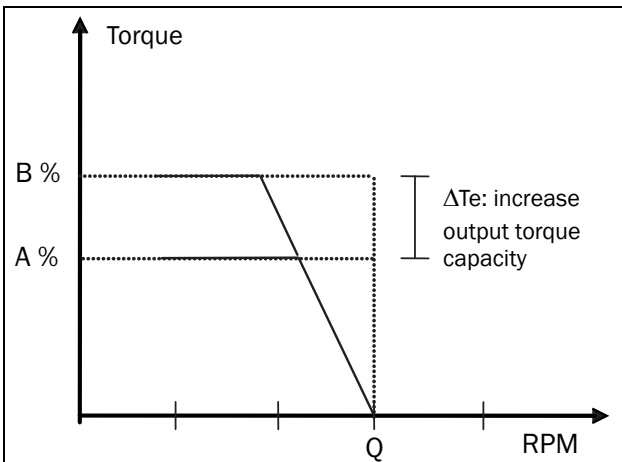

Fig. 27 Output Torque Capacity

A=without torque boost

B=with torque boost

- Operating frequency range: 0 to Motor rate frequency
- Increase the value in menu [351] if the motor torque is too low.

- Decrease the value in menu [351] if the motor behaviour gets erratic.
- The max. Output torque limit to the VSD is current rated.
- If the current gets too high when increasing the value in menu [351] also increase the value in menu [354].

352 Low frequency voltage compensation, [211]=000

Performance: During low frequency

Increase [352] setting value to increase output voltage and low frequency torque.

Decrease [352] setting value to decrease output voltage and low frequency torque.

- Output voltage/frequency curve pattern:

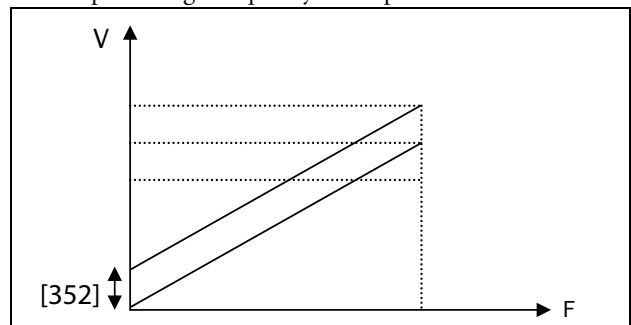

Fig. 28 Low Frequency Voltage Compensation

- Operating frequency range: 0–12 Hz/60 Hz, 0–10 Hz/ 50 Hz
- During low frequency use:

When the motor output torque is insufficient, increase [352] setting value.

When the motor is vibrating excessively, decrease [352] setting value.

353 Preset V/F patterns =1 to 7

[353]=007. Select user-set V/F pattern in menus [355] to [35A].

See the diagram below. Care should be taken when this feature is used as improper setting of these parameters will have an adverse effect on motor performance.

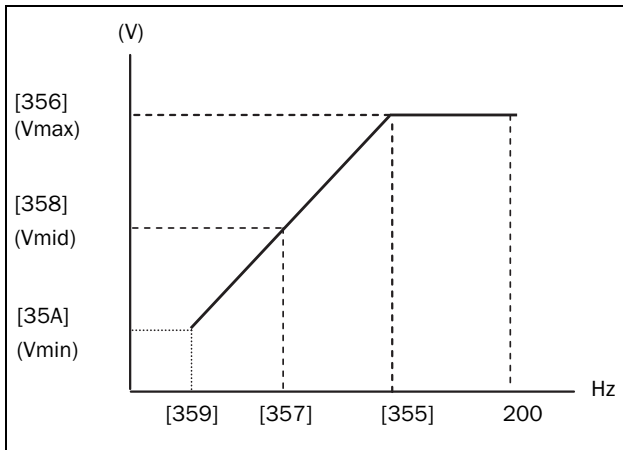

Fig. 29 User configured V/F pattern

[353]=001 to 006 fixed V/F patterns (see below).

Spec	Purpose	[353]	V/F Pattern	Spec	Purpose	[353]	V/F Pattern
50 Hz System	General	001		60 Hz System	General	004	
	High starting torque	002			High starting torque	005	
	Variable torque	003			Variable torque	006	

Fig. 30 Pre-configured V/F patterns

354 Slip compensation gain (vector), [211]=000

Performance: If the motor load appears too large, increase slip compensation.

$$\Delta F_{slip} = I \times \text{Gain}$$

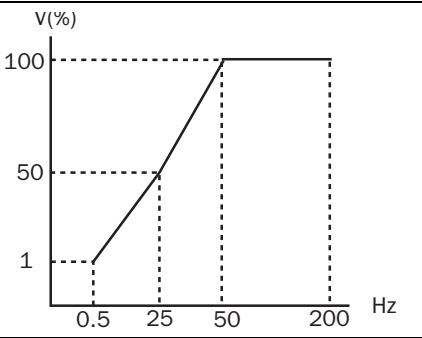
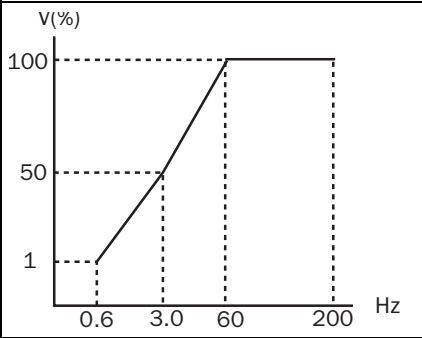
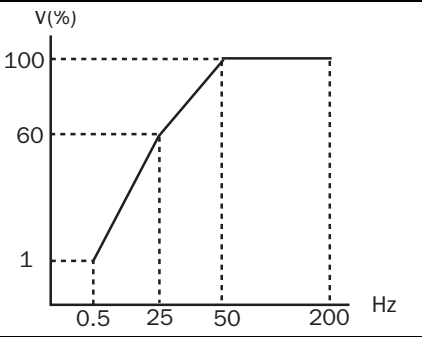
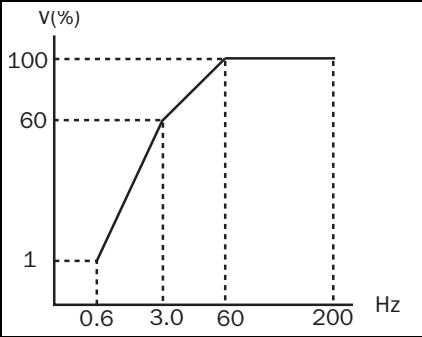
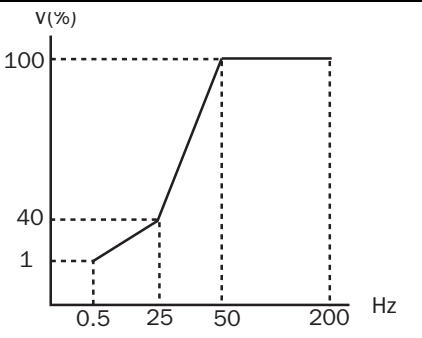
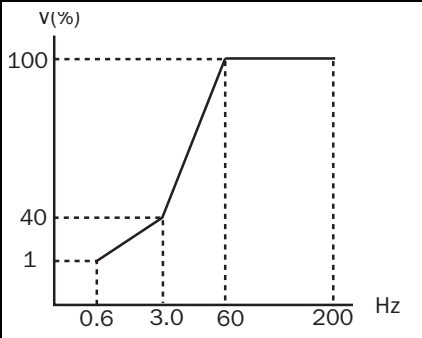
I=load current

Gain= compensation gain

- Torque/Speed curve pattern:

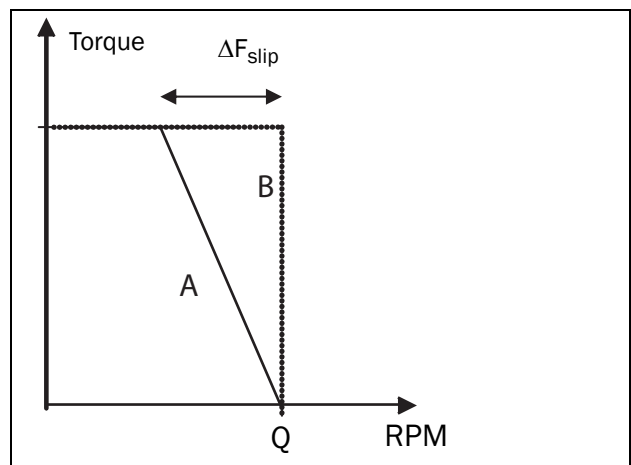

Fig. 31 Slip Compensation

A=without slip compensation

B=with slip compensation

- Operating frequency range: 0 to motor rated frequency.
- When the motor output rotation speed is too low increase [354] setting value.
- When the motor is erratic or vibrates, decrease [351] setting value.
- The max. output rotation speed limit to the motor max. setting frequency.

If the current gets too high when increasing the value in menu [354] also increase the value in menu [351].

Set frequency priority: Jog Preset frequency External analogue frequency signal

Preset Frequency Command 3 Set value =004	Preset Frequency Command 2 Set value =003	Preset Frequency Command 1 Set value =002	Jog frequency Command Set value =005	Output frequency
0	0	0	0	362
0	0	1	0	363
0	1	0	0	364
0	1	1	0	365
1	0	0	0	366
1	0	1	0	367
1	1	0	0	368
1	1	1	0	369
X	X	X	1	348

[355] Max. output frequency (HZ)	50.0 to 200 Hz
[356] Output voltage ratio at max. frequency (%)	00.0 to 100%
[357] Mid frequency (HZ)	00.1 to 200 Hz
[358] Output voltage ratio at mid. frequency (%)	00.0 to 100%
[359] Min. output frequency (HZ)	00.1 to 200 Hz
[35A] Output voltage ratio at min. frequency (%)	00.0 to 100%

[355] to [35A] please refer to [353] description

35B Torque Boost Gain (V/F) (%) 00.0 to 30.0%

35C Slip Compensation Gain (V/F) (%) 00.0 to 100%

361 Frequency Up/Down control using MFIT:

000: When using Up/Down command, the set frequency by this function will be stored after the VSD stops. The Up/Down function is not available in stop mode.

001: When using Up/Down command, the set frequency will be reset to 0 Hz after the VSD stops.

002: When using Up/Down command, the set frequency will be stored after the VSD stops. Up/Down function is available in stop mode.

1. [361]=000: when the RUN signal is ON, the VSD will accelerate to the [362] setting then continue to run at the set command speed. When Up/Down terminal is activated, the VSD begins to accelerate/decelerate until the signal is released then. It run at the reached speed.

When the RUN signal is OFF, the VSD decelerates to stop (or coasts to stop) according to the setting of [337]. The last output frequency when the RUN signal is OFF, will be stored in [362].

The Up/Down key is unavailable in stop. The stored frequency can not be changed by Up/Down

Terminal, but can be changed by the content of [362] by keypad.

2. [361]=001: the VSD will run from 0 Hz as the run signal is applied.
Up/Down operation method is same as [361]=000. But on next RUN signal is ON, VSD always starts up from 0Hz.

[361]=002: Same as when [361]=001 but Up/Down is available while in stop mode.

Menu	Description	Frequency range	Factory default
362	Preset frequency 1 (Hz)	00.0 - 200	05.0
363	Preset frequency 2 (Hz)	00.0 - 200	05.0
364	Preset frequency 3 (Hz)	00.0 - 200	10.0
365	Preset frequency 4 (Hz)	00.0 - 200	20.0
366	Preset frequency 5 (Hz)	00.0 - 200	30.0
367	Preset frequency 6 (Hz)	00.0 - 200	40.0
368	Preset frequency 7 (Hz)	00.0 - 200	50.0
369	Preset frequency 8 (Hz)	00.0 - 200	60.0

381 PID operation mode

000: PID Function disabled.

001: PID Control, Deviation is derivative controlled.

002: PID Control, Feedback is derivative controlled.

003: Same as 001 but (reverse characteristics control).

004: Same as 002 but (reverse characteristics control).

[381]=1: D is the deviation of PID error in the unit time [385].

=2: D is the deviation of feedback value in the unit time [385].

=3: D is the deviation of PID error in the unit time [385]. If the deviation is positive, the output frequency decreases, and vice versa.

=4: D is the deviation of feedback value in unit time [385]. When the deviation is positive, the frequency decreases, and vice versa..

382 PID offset
000: Positive direction
001: Negative direction

383 P: Proportional gain: 0.00-10.0

[383]: Proportional gain for P control.

384 I: Integral time (s): 00.0-100

[384]: Integral time for I control

385 D: Differential time (s): 0.00 - 10.0

[385]: Differential time for D control

411: Alarm select: 000 - 001
000: Off, No alarm functions active.
001: Min, Min Alarm active. The alarm output functions as an underload alarm.
002: Max, Max Alarm active. The alarm output functions as an overload alarm.
003: Max+Min, Both Max and Min alarm are active. The alarm outputs function as overload and underload alarms.

The monitor functions enable the VSD to be used as a load monitor. Load monitors are used to protect machines and processes against mechanical overload and underload, e.g. a conveyer belt or screw conveyer jamming, belt failure on a fan and a pump dry running.

Selects the types of alarms that are active.

412: Alarm trip: 000 - 001
000: Off, No alarm functions active.
001: Min, Min Alarm active. The alarm output functions as an underload alarm.
002: Max, Max Alarm active. The alarm output functions as an overload alarm.
003: Max+Min, Both Max and Min alarm are active. The alarm outputs function as overload and underload alarms.

Selects which alarm must cause a trip to the VSD.

413 Ramp Alarm
000: Off, (Pre) alarms are inhibited during acceleration/ deceleration
001: On, (Pre) alarms active during acceleration/deceleration.

This function inhibits the (pre) alarm signals during acceleration/deceleration of the motor to avoid false alarms.

414 Alarm Start Delay: 0-3600

This parameter is used if, for example, you want to override an alarm during the start-up procedure.

Sets the delay time after a run command, after which the alarm may be given.

If Ramp Alarm=On. The start delay begins after a RUN command.

If Ramp Alarm=Off. The start delay begins after the acceleration ramp.

415 Load Type
000: Basic, Uses a fixed maximum and minimum load level over the full speed range. Can be used in situations where the torque is independent of the speed.
001: Load Curve, Uses the measured actual load characteristic of the process over the speed range.

In this menu you select monitor type according to the load characteristic of your application. By selecting the required monitor type, the overload and underload alarm function can be optimized according to the load characteristic.

When the application has a constant load over the whole speed range, i.e. extruder or screw compressor, the load type can be set to basic.

When the load of the application does vary over the speed range i.e. centrifugal pump or a fan, the load type can be set to load curve to achieve accurate protection over the whole speed range.

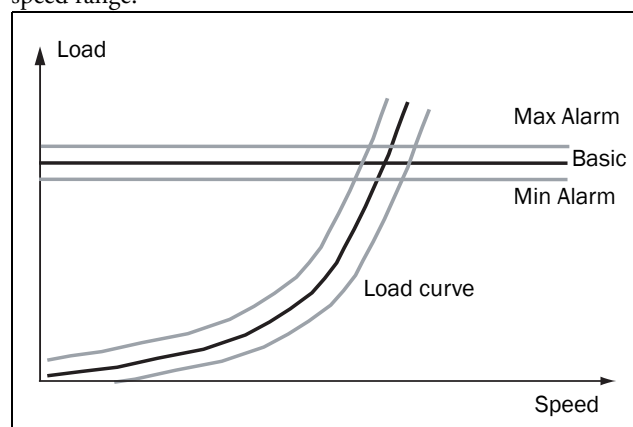

416 Max Alarm Margin: 0-400%

The max alarm margin sets the allowed deviation level for generating an overload alarm. This margin will be added to the normal load [415] or load curve [41C] depending on the set in menu [415] Load Type.

417 Max Alarm Delay: 0-90 s

Sets the delay time between the first occurrence of max alarm condition and after when the alarm is given.

418 Max Pre Alarm Margin: 0-400%

The max pre alarm margin sets the allowed deviation level for generating an overload pre alarm. This margin will be added to the normal load [415] or load curve [41C] depending on the set in menu [415] Load Type.

419 Max Pre Alarm Delay: 0-90 s

Sets the delay time between the first occurrence of max pre alarm condition and after when the alarm is given.

41A Min Pre Alarm Margin: 0-400%

The min pre alarm margin sets the allowed deviation level for generating an underload alarm. This margin will be added to the normal load [415] or load curve [41C] depending on the set in menu [415] Load Type.

41B Min Pre Alarm Delay: 0-90 s

Sets the delay time between the first occurrence of min pre alarm condition and after when the alarm is given.

41C Min Alarm Margin: 0-400%

The min alarm margin sets the allowed deviation level for generating an underload alarm. This margin will be added to the normal load [415] or load curve [41C] depending on the set in menu [415] Load Type.

41D Min Alarm Delay: 0-90 s

Sets the delay time between the first occurrence of min alarm condition and after when the alarm is given.

41E Autoset Alarm:

000: No
001: Yes

When load type [415] is set to basic, the auto set function sets the actual load level at 100% and accompanying alarm levels automatically. When load type [415] is set to load curve, the auto set function will perform a test run to measure the actual load at the defined 9 sample speed references. The VSD will then run the motor from min to max speed.



WARNING: When auto test does a test run the motor and application/machine will start!

41F Normal Load: 0-400% of max torque

Set the level of the normal load. The alarm or pre alarm will be activated when the load is above/under normal load \pm margin.

NOTE: 100% Torque means: $I_{NOM} = I_{MOT}$. The maximum depends on the motor current and VSD max current settings, but the absolute maximum adjustment is 400%.

421 to 429 Load Curve 1 to 9: 0-400% of max torque

The function should be used only for loads with quadratic load curve.

The measured load curve is based on 9 stored samples. The curve starts at minimum speed and ends at maximum speed, the range in between is divided into 7 equal steps. The measured values of each sample are displayed in [421] to [429] and can be adapted manually. The value of the 1st sampled value on the load curve is displayed.

NOTE: These values are read only and cannot be changed.

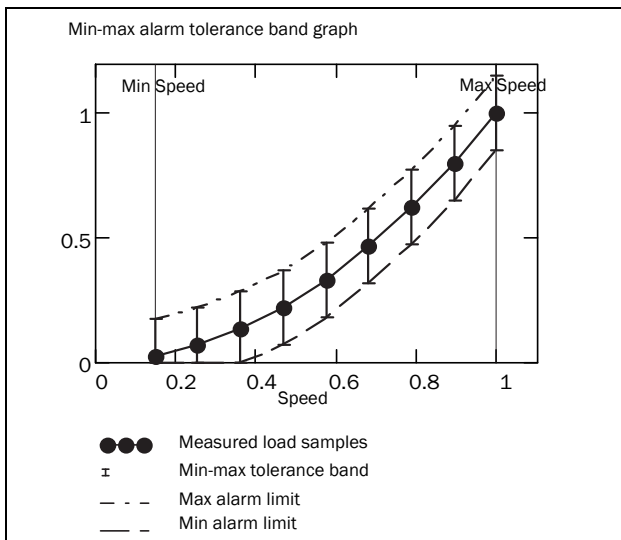

432 Motor no load current (A)

Motor no load current varies with VSD capacity [921]. Please adjust according to the actual conditions.

433 VF base output voltage set

At [433]=60 Hz

[356]=100%

For 200 to 240 V, patterns based on output voltage are shown below. (Corresponding settings for 400-480 volts input: multiply by 2).

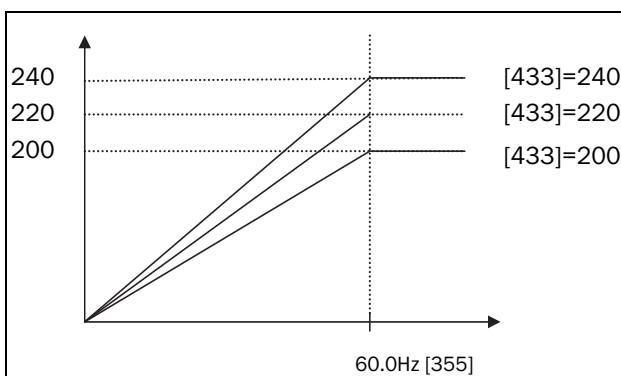

Fig. 32 V/Hz curves with varying base voltages

When the output voltage is set higher than the input voltage, the max output voltage is limited to the max input voltage.

511 Analogue input

Selectable Functions for analogue input terminals (AIN)

- 000: Forward run
- 001: Reverse run
- 002: Preset speed command 1
- 003: Preset speed command 2
- 004: Preset speed command 3
- 005: Jog frequency command
- 006: External Emergency stop(E.S.)
- 007: Base block (b.b.)
- 008: Switch to 2nd acceleration/ deceleration time
- 009: Reset
- 010: Up command
- 011: Down command
- 012: Control signal switch
- 013: Communication mode. Disable – Enable.
- 014: Acceleration/deceleration prohibit
- 015: Master/Auxiliary speed switch
- 016: PID function prohibit
- 017: Analog frequency signal input (terminal AIN)
- 018: PID feedback signal (terminal AIN)
- 019: DC Brake signal

1. AIN on TM2 are multi-function input terminals which can be set to the above 19 functions.

2. [511] function description:

[511]=000/001(Forward/ Reverse)

Forward command ON sets the VSD running forward, while OFF stops the VSD. [521] factory default is forward command.

Reverse command ON sets the VSD running reverse, While OFF, the VSD stops. [522] factory default is reverse command.

If via different digital inputs both the commands Forward and Reverse are ON, the VSD will go in Stop mode.

[511]=002 to 004 (Preset speed command 1 to 3)

When run signal is applied and the selected external multi-function input terminal is on, the VSD will run at one of 8 preset speeds which are controlled by the status of the terminals. The corresponding speeds are programmed in parameters [362] to [348] as shown in the table below.

[511]=005 (Jog frequency command)

When run signal is applied and the selected external multi-function input terminal is on and set to Jog speed, the VSD will run according to [348] setting.

Priority of the frequencies: Jog > preset speed.

Preset Speed Command 3 Set value =004	Preset Speed Command 2 Set value =003	Preset Speed Command 1 Set value =002	Jog Frequency Command Set value =005	Output frequency set value
X	X	X	1	[348]
0	0	0	0	[362]
0	0	1	0	[363]
0	1	0	0	[364]
0	1	1	0	[365]
1	0	0	0	[366]
1	0	1	0	[367]
1	1	0	0	[368]
1	1	1	0	[369]

[511]=006: Emergency Stop (E.S)

The VSD will decelerate to stop on receiving the external emergency stop signal.

The display will be flashing "E.S".

The VSD will only start again when the Emergency Stop signal is removed and the start signal is turned off and then on again (remote start mode) or the Run key is pressed (keypad mode).

Removing the Emergency Stop signal before the VSD has fully stopped will not inhibit the Emergency Stop operation.

Output relay can be set to Emergency. Stop fault by setting [551]=008

[511]=007: Base Block (b.b.)

The VSD will stop immediately on receiving the Base Block signal regardless of the setting of [337] and blink "b.b". The VSD will auto restart at speed search when the Base Block signal is released.

[511]=008: Switching to 2nd acceleration/ deceleration time.

When the external terminal is ON it selects the 2nd acceleration/ deceleration time. (see parameters [333], [334])

[511]=009: Reset command

When the reset command ON, the VSD will be disabled. Reset table faults will be cleared.

[511]=010/011: Up/Down function: (Controlled by acceleration/deceleration times)

Set [212]=003, to enable the Up/Down function. Note: the Up/Down key on the keypad is unavailable for changing frequency directly.

Set [361]=000, When Up/Down terminal is ON, the VSD begins acceleration/deceleration to a frequency and

stops acceleration/ deceleration when the Up/ Down signal has been released. The drive continues to run at the most recent set speed.

The VSD will decelerate to stop or free run to stop when the run command is OFF according to [337]. The speed at which the VSD stops will be stored in [362].

NOTE: Up/Down key is now unavailable for modifying frequency. It should be modified in menu [362].

Set [361]=001, The VSD will run from 0 Hz when receiving run command.

Up/Down action is similar to the above description. When the run command is released, the VSD will decelerate to stop or free run to stop (0 Hz) according to the setting in menu [337].

The VSD will output from 0 Hz in next operation.

Note: Up/Down commands are disabled if both terminals are ON at the same time.

[511]=012: Control signal switch

External control terminal OFF: operation signal/frequency signal is controlled by menu [212]/[213].

External control terminal ON: Operation signal/frequency signal is controlled by keypad display.

[511]=013: Communication mode select.

External control terminal OFF: in communication, the VSD is controlled by master (PC or PLC) run/frequency signal and allows parameter modification. The keypad and TM2 run/frequency signal is not available for the VSD at this time. The keypad is only available for display of voltage/current/ frequency and read parameters but cannot modify them. It is also available for emergency stop.

External control terminal ON: PC/PLC can read and modify menus. But all controls are from the keypad. (Not affected by settings in menu [212]/[213]).

[511]=014: Acceleration/deceleration Disable.

When the external control terminal ON, the VSD will stop acceleration/ deceleration will the signal is released. The motion is as follows:

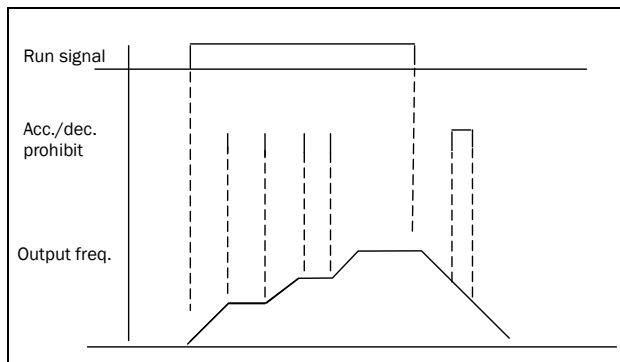

Fig. 33 Acceleration/Deceleration Prohibit

NOTE: Acceleration/deceleration prohibit is unavailable if the Run signal is OFF (Ramp to stop).

[511]=015 Master/Auxiliary speed switch

- [212]=001, when one of the menus [521] to [524] is set to 015, and multi-function input terminal is OFF, the frequency is set by the potentiometer on the keypad (master speed), When the multi-function input terminal is ON, the frequency is set by the analogue signal on TM2 (Auxiliary speed AIN).
- [212]=002, when one of the menus [521] to [524] is set to 015, and multi-function input terminal is OFF, the frequency is set by the analogue signal on TM2, (Master Auxiliary speed AIN); While multi-function input terminal is ON, the frequency is set by the potentiometer on the keypad (auxiliary speed).

[511]=016 (PID function disable)

When input terminal is on, PID functions set in menu [381] are disabled.

When input terminal is the PID functions are enabled.

[511]=017 Analog frequency signal input (Terminal AIN)

Frequency reference can be set by 0-10 VDC or 4-20 mA on terminal AIN as set in menu [512] and SW2.

[511]=018 PID Feedback signal input (Terminal AIN)

PID feedback can be connected to AIN terminal 0-10 VDC/0-20 mA or 2-10 V/4-20 mA as set in menu [512] and SW2. The PID setpoint is selected by menu [212]:

- [212]=000 Up/Down keys used for PID setpoint
 [212]=001 Potentiometer on keypad used for PID setpoint

[511]=019 DC Brake signal

When TM2 DC Brake signal is OFF, and the brake time of [338] has not been over, then brake time is according to set value of [338]; When TM2 DC Brake signal is ON, and the brake time in menu [338] has already been over, the brake is stopped according to DC Brake signal OFF of TM2, and DC brake level is decreased to 2,5% to avoid motor overheat.

Caution: the motor will be easily overheated if the DC brake time is set too long. Make sure that the heat dissipation of the motor is within limits to avoid motor failure

512 AIN signal select

000: 0-10V/0-20 mA

001: 2-10V/4-20 mA

[512]: AIN signal select: set SW2 to appropriate V/I signal selection

[512]=000: 0-10 V/0-20 mA

[512]=001: 2-10 V/4-20 mA

513 AIN signal scan time confirmation. (ms × 8): 001 to 100

514 AIN Gain (%) 000 - 200

515 AIN Bias (%) 000 - 100

- [516]= 000: 0 V (4 mA) corresponding to lower frequency limit, 10 V (20 mA) corresponding to upper frequency limit.
- [516]= 001: 10 V (20 mA) corresponding to lower frequency limit, 0 V (4 mA) corresponding to upper frequency limit.

The setting of figure 1:

	514	515	516	517
A	100%	050%	000	000
B	100%	000%	000	000

The setting of figure2:

	514	515	516	517	514
C	100%	050%	000	001	100%
D	100%	000%	000	001	100%

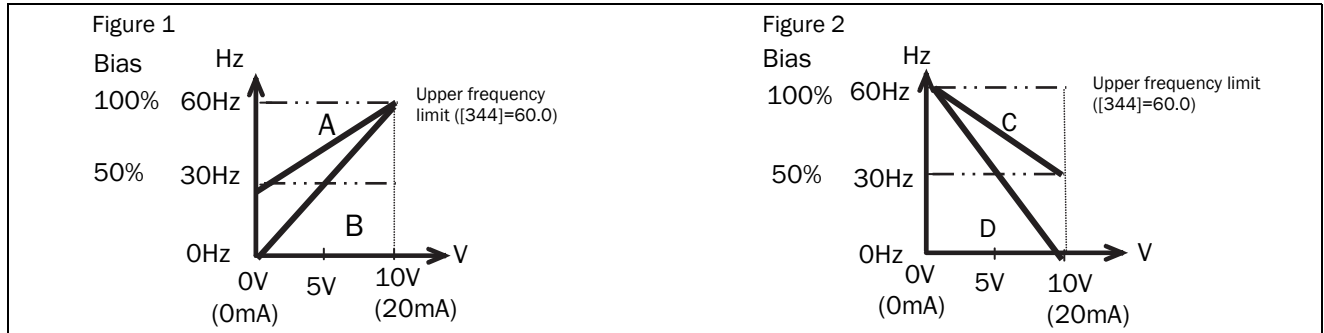

The setting of figure 3:

	514	515	516	517
E	100%	020%	001	000

The setting of figure 4:

	514	515	516	517
F	100%	050%	001	001

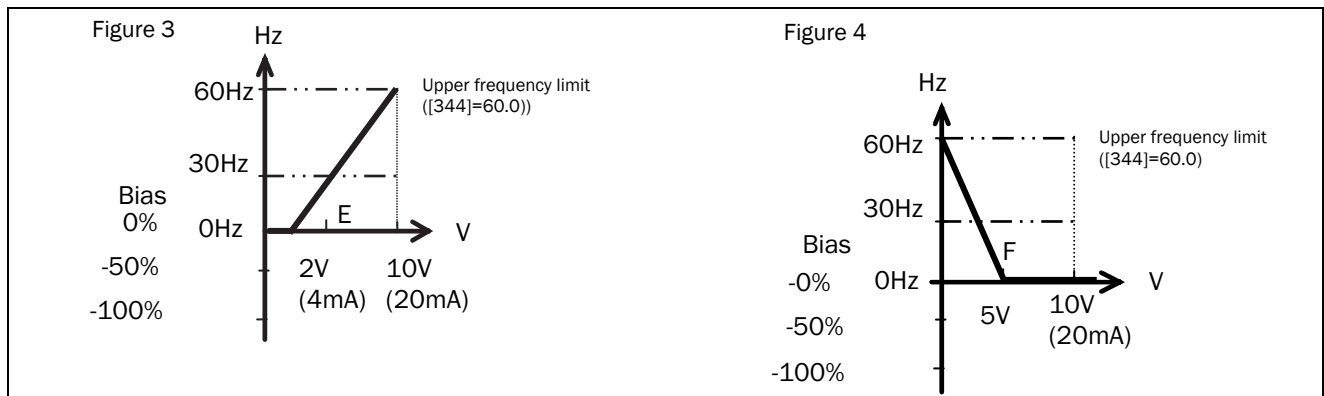

516 AIN Bias:
 000: Positive
 001: Negative
 517 AIN signal slope direction.
 000: Positive
 001: Negative

Refer to [514]/[515] description.

The VSD reads A/D average value every [513] x 8 ms. The user can set scan interval time according to noise levels in the operation environment. Extend [513] if noise is a problem, however the response speed will be slower.

518: Multi-function input terminal S1 to S6 signal scan time (N. ms x 8), N=(1 to 100 times).

1. If the [518] scan time is set to 80 ms as an example (i.e N=10) then digital input signals on for less than 80 ms will be ignored.
2. If the scan signal is seen for N times (scan times), the VSD takes it as signal change. If it is seen for less than N times, it is seed as noise. One scan time: 8 ms.
3. User can set scan interval time according to noise in the operation environment. Extend [518]/[513] if noise is a problem, however this will reduce the scan response time.

521 to 524

Selectable Functions for input terminals (S1-S4)

- 000: Forward run
- 001: Reverse run
- 002: Preset speed command 1
- 003: Preset speed command 2
- 004: Preset speed command 3
- 005: Jog frequency command
- 006: External Emergency stop(E.S.)
- 007: Base block (b.b.)
- 008: Switch to 2nd acceleration/ deceleration time
- 009: Reset
- 010: Up command
- 011: Down command
- 012: Control signal switch
- 013: Communication mode. Disable – Enable.
- 014: Acceleration/deceleration prohibit
- 015: Master/Auxiliary speed switch
- 016: PID function prohibit
- 019: DC Brake signal
- 020: Enable

1. S1-S4 on TM2 are multi-function input terminals which can be set to the above 19 functions.

2. [521] to [524] function description:

[521] to [524]=000/001(Forward/ Reverse)

Forward command ON sets the VSD running forward, while OFF stops the VSD. [521] factory default is forward command.

Reverse command ON sets the VSD running reverse, While OFF, the VSD stops. [522] factory default is reverse command.

If forward –reverse command are ON at the same time the VSD is in Stop mode.

[521] to [524]=002 to 004 (Preset speed command 1 to 3)

When run signal is applied and the selected external multi-function input terminal is on, the VSD will run at one of 8 preset speeds which are controlled by the status of the terminals. The corresponding speeds are programmed in parameters [362] to [348] as shown in the table below.

[521] to [524]=005 (Jog frequency command)

When run signal is applied and the selected external multi-function input terminal is on and set to Jog speed, the VSD will run according to [348] setting.

Priority of the frequencies: Jog > preset speed.

Preset Speed Command 3 Set value =004	Preset Speed Command 2 Set value =003	Preset Speed Command 1 Set value =002	Jog Frequency Command Set value =005	Output frequency set value
X	X	X	1	[348]
0	0	0	0	[362]
0	0	1	0	[363]
0	1	0	0	[364]
0	1	1	0	[365]
1	0	0	0	[366]
1	0	1	0	[367]
1	1	0	0	[368]
1	1	1	0	[369]

[521] to [524]=006: Emergency Stop (E.S)

The VSD will decelerate to stop on receiving the external emergency stop signal.

The display will be flashing “E.S”.

The VSD will only start again when the Emergency Stop signal is removed and the start signal is turned off and then on again (remote start mode) or the Run key is pressed (keypad mode).

Removing the Emergency Stop signal before the VSD has fully stopped will not inhibit the Emergency Stop operation.

Output relay can be set to Emergency. Stop fault by setting [551]=008

[521] to [524]=007: Base Block (b.b.)

The VSD will stop immediately on receiving the Base Block signal regardless of the setting of [337] and blink “b.b”. The VSD will auto restart at speed search when the Base Block signal is released.

[521] to [524]=008: Switching to 2nd acceleration/ deceleration time.

When the external terminal is ON it selects the 2nd acceleration/ deceleration time. (see parameters [333], [334])

[521] to [524]=009: Reset command

When the reset command is ON, the VSD will be disabled. Reset table faults will be cleared.

[521] to [524]=010/011: Up/Down function: (Controlled by acceleration/deceleration times)

Set [212]=003, to enable the Up/Down function. Note: the Up/Down key on the keypad is unavailable for changing frequency directly.

Set [361]=000, When Up/Down terminal is ON, the VSD begins acceleration/deceleration to a frequency and stops acceleration/ deceleration when the Up/ Down sig-

nal has been released. The drive continues to run at the most recent set speed.

The VSD will decelerate to stop or free run to stop when the run command is OFF according to [337]. The speed at which the VSD stops will be stored in [362].

NOTE: Up/Down key is now unavailable for modifying frequency. It should be modified in menu [362].

Set [361]=001, The VSD will run from 0 Hz when receiving run command.

Up/Down action is similar to the above description. When the run command is released, the VSD will decelerate to stop or free run to stop (0 Hz) according to the setting in menu [337].

The VSD will output from 0 Hz in next operation.

Note: Up/Down commands are disabled if both terminals are ON at the same time.

[521] to [524]=012: Control signal switch

External control terminal OFF: operation signal/frequency signal is controlled by menu [212]/[213].

External control terminal ON: Operation signal/frequency signal is controlled by keypad display.

[521] to [524]=013: Communication mode select.

External control terminal OFF: in communication, the VSD is controlled by master (PC or PLC) run/frequency signal and allows parameter modification. The keypad and TM2 run/frequency signal is not available for the VSD at this time. The keypad is only available for display of voltage/current/ frequency and read parameters but cannot modify them. It is also available for emergency stop.

External control terminal ON: PC/PLC can read and modify menus. But all controls are from the keypad. (Not affected by settings in menu [212]/[213]).

[521] to [524]=014: Acceleration/deceleration Disable.

When the external control terminal ON, the VSD will stop acceleration/ deceleration will the signal is released. The motion is as follows:

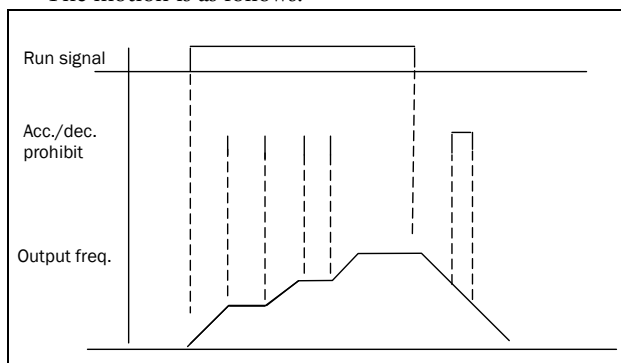

Fig. 34 Acceleration/Deceleration Prohibit

NOTE: Acceleration/deceleration prohibit is unavailable if the Run signal is OFF (Ramp to stop).

[521] to [524]=015 Master/Auxiliary speed switch

1. [212]=001, when one of the menus [521] to [524] is set to 015, and multi-function input terminal is OFF, the frequency is set by the potentiometer on the keypad (master speed), When the multi-function input terminal is ON, the frequency is set by the analogue signal on TM2 (Auxiliary speed AIN).

2. [212]=002, when one of the menus [521] to [524] is set to 015, and multi-function input terminal is OFF, the frequency is set by the analogue signal on TM2,

(Master Auxiliary speed AIN); While multi-function input terminal is ON, the frequency is set by the potentiometer on the keypad (auxiliary speed).

[521] to [524]=016 (PID function disable)

When input terminal is on, PID functions set in menu [381] are disabled.

When input terminal is the PID functions are enabled.

[521] to [524]=019 DC Brake signal

When TM2 DC Brake signal is OFF, and the brake time of [338] has not been over, then brake time is according to set value of [338]; When TM2 DC Brake signal is ON, and the brake time in menu [338] has already been over, the brake is stopped according to DC Brake signal OFF of TM2.

[521] to [524] = 020 Enable command

When one of the menus [521] to [524] is set to 020, the related multi-function terminal (digital input) need to be activated to create a general start condition and allow the VSD to activate the output and run the connected motor, according the selections in [213] and [215].

Enable is active when:

SW1= PNP and multi-function input terminal is made 'High' (+24V)

SW1= NPN and multi-function input terminal is made 'Low' (Common)

If the multi-function terminal is made inactive during running, the output of the VSD is cut off immediately, causing the motor to coast to zero speed, and the display will show "b.b". After activating the Enable input again, a new Run command is needed to start the motor.

525/526 (option card)
 S5/S6 terminal on MFIT Setting

000: Forward
 001: Reverse
 002: Preset speed command 1
 003: Preset speed command 2
 004: Preset speed command 3
 005: Jog Frequency Command
 006: Emergency Stop (E.S.)
 007: Base Block (b.b.)
 008: Switching to 2nd acceleration/ deceleration time.
 009: Reset
 010: Up Command
 011: Down Command
 012: Control signal switch
 013: Communication control signal switch
 014: Acceleration/ deceleration disable
 015: Master/ auxiliary speed switch
 016: PID function disable
 019: DC brake signal
 020: Enable

Refer to [521] to [524]

Multi-function analogue output:
 [531] Multi-function output analogue type selection

001: Set frequency
 002: Output frequency
 003: DC voltage
 004: Output current
 005: PID feedback signal

[532] Multi-function analogue output gain = 000 to 200%

0-10 VDC output from the FM+ multi-function analogue output terminal.

Output can be set to any of the above selections.

[531]=005, PID Feedback. The analogue input to terminal AIN (0-10 VDC or 4-20 mA), will be outputted from terminal FM+ as 0-10 VDC.

[532] is used to scale the output signal supplied to the externally connected analogue device.

NOTE: Due to hardware limits, the max output voltage from FM+ terminal will be limited to 10 V.

Examples

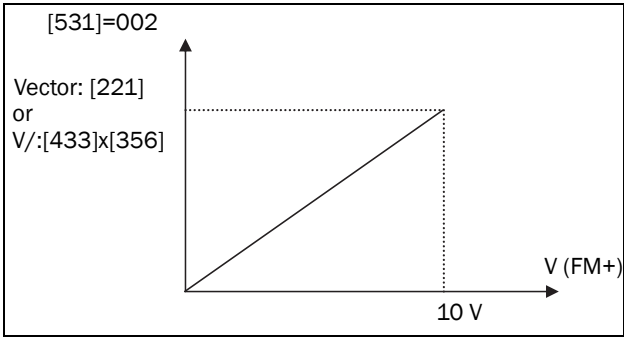
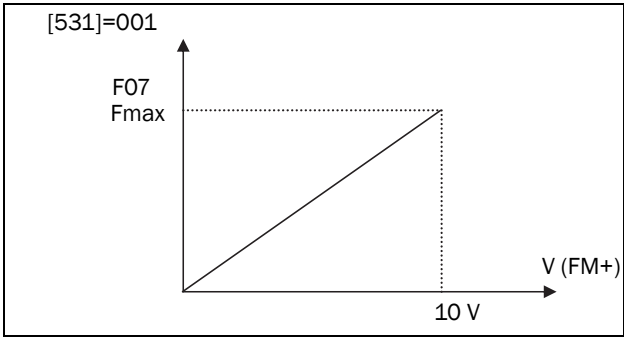
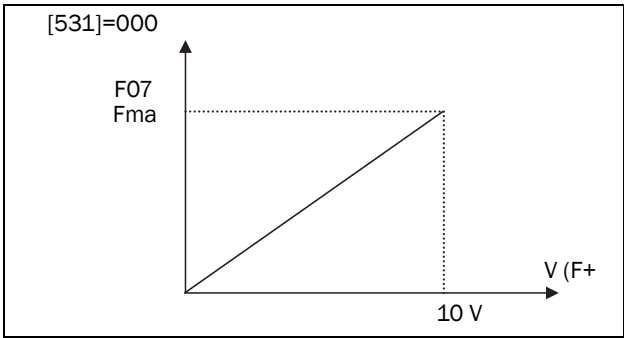

1. When [211]=0 (vector FM+ 0-10 V corresponds to 0-motor rated voltage [211])
2. When [211]=1 (V/F) FM+ 0-10 V corresponds to 0-V/F base output voltage set [433]xMax output frequency voltage ratio % [356].

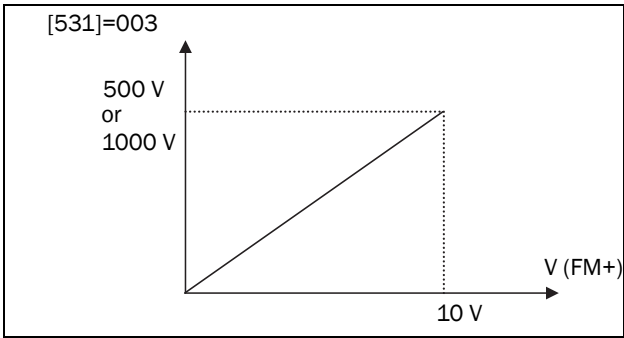

- 200 V class: FM+ 0-10 V corresponds to 0-500 VDC.
 400 V class: FM+ 0-10 V corresponds to 0-1000 VDC.

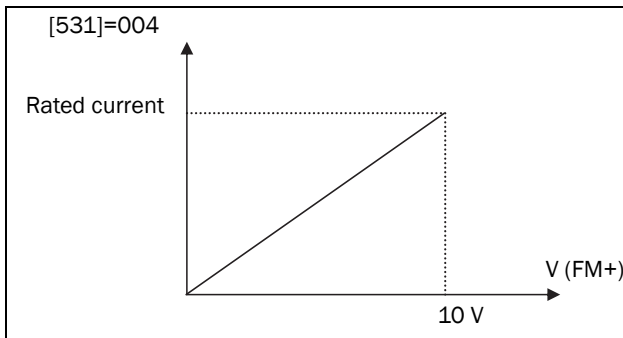

Example: the rated current of VSA23-04 is 4.5 A, FM+ 0-10 V corresponds to 0-4.5 A.

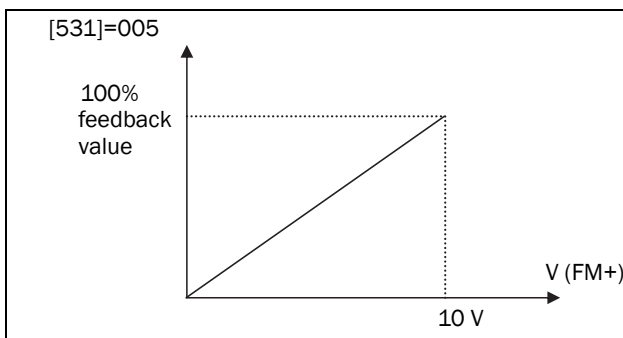

1. When [381]≠0, FM+ 0-10 V corresponds to 0-100% feedback value.
2. When [381]=0 FM+ 0-10 V corresponds to 0-10 V or 0-20 mA on S6.

Keypad, jog, and preset frequency setting (MFIT):

NOTE 1: Frequency selection will be made according to the setting of terminals S1-S4 & AIN and also setting of parameters [521] to [524] as required.

NOTE 2: Selected preset frequency values should be programmed in parameters [362] to [369] as required.

1. [521] to [524]=002 to 004 (Preset frequency command 1 to 3)
When the run signal is applied and any of the selected multi-function input terminals is ON, the VSD will run at the preset frequency according to the table below.
2. [521] to [524]=005 (Jog frequency command)

External input terminal is set to Jog operation. When ON, the VSD will run at Jog frequency.

541 (Option card) Multi-function output T+, T-

- 000: Run
- 001: Frequency reached [Preset target frequency ±[612]]
- 002: Frequency reached [Preset output frequency level [611] ±[612]]
- 003: Frequency detection (>[611])
- 004: Frequency detection (<[611])
- 005: Fault.
- 006: Auto-restart
- 007: Momentary power loss
- 008: Emergency Stop (E.S.)
- 009: Base Block (b.b.)
- 010: Motor overload protection
- 011: VSD overload protection
- 012: Reserved
- 013: Power ON
- 014: Communication error
- 015: Output current detection (>[613])
- 016: No Fault

Refer to [551] description.

551 Multi function output RY1

- 000: Run
- 001: Frequency reached (Preset target frequency ± [612])
- 002: Frequency reached (Preset output frequency level [611] ±[612])
- 003: Frequency Detection (>[611])
- 004: Frequency Detection (<[611])
- 005: Fault output
- 006: Auto restart
- 007: Momentary power loss
- 008: Emergency Stop(E.S.)
- 009: Base Block(b.b.)
- 010: Motor overload protection
- 011: VSD overload protection
- 012: Reserved
- 013: Power On
- 014: Communication error
- 015: Output current detection (>[613])
- 016: No Fault

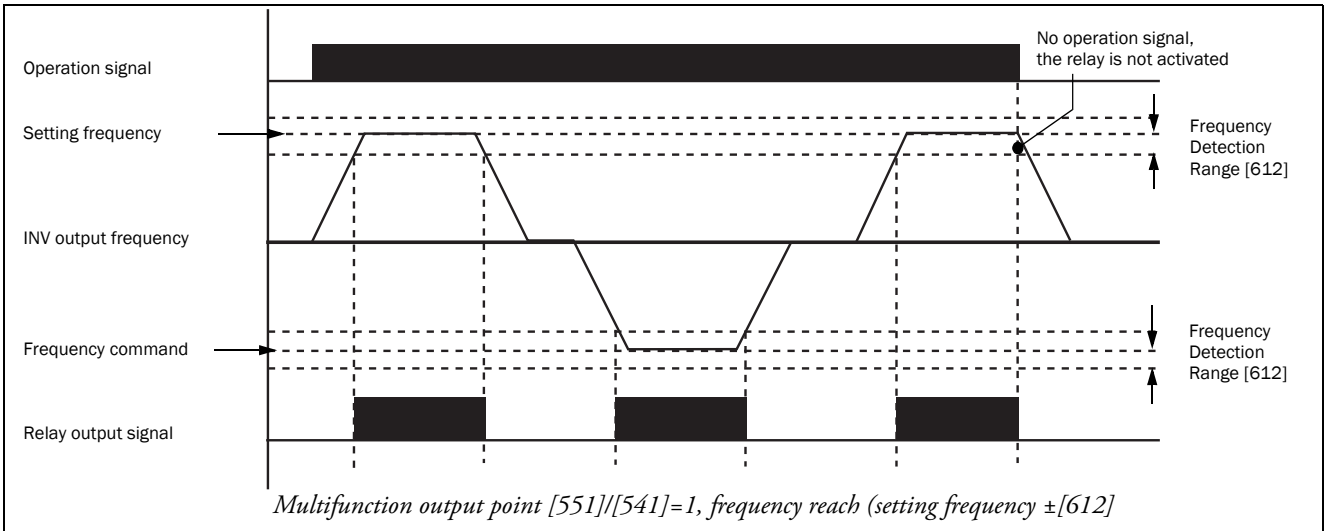

Fig. 35 Frequency Reached, [551]/[541]=1

[551]/[541]=002 Preset output frequency [611] \pm [612] reached

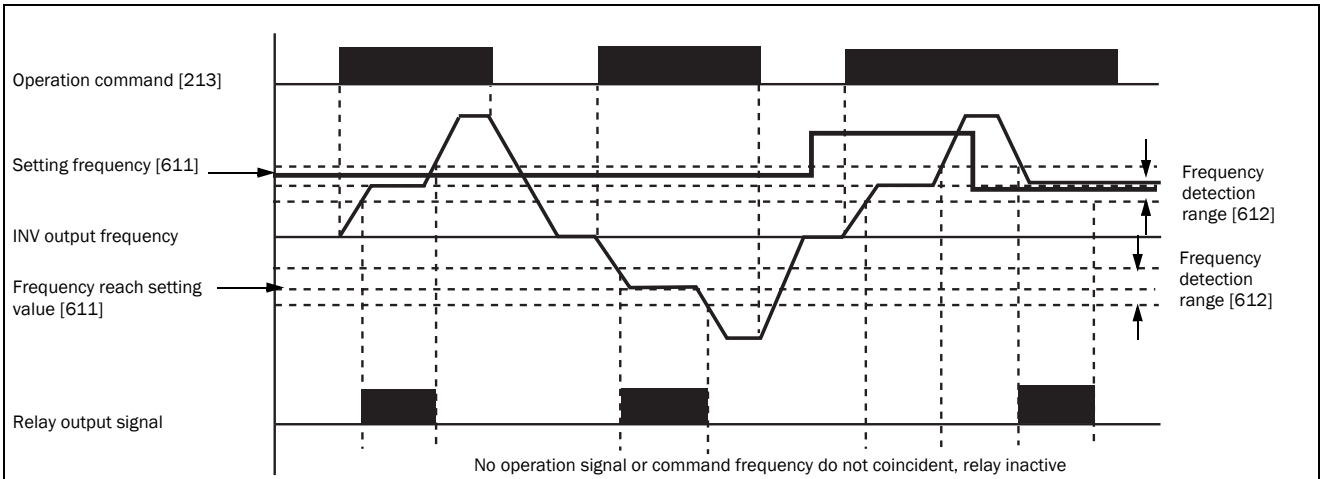

Fig. 36 Frequency Reached [551]/[541]=2

[551]/[541]=003 Frequency detection fout > [611]

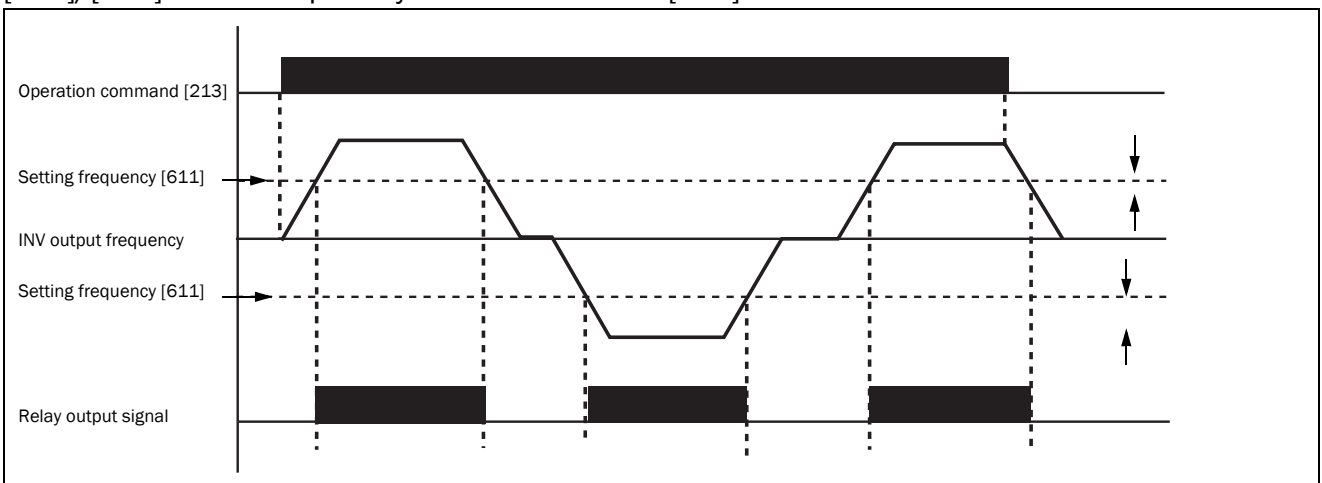

Fig. 37 Frequency Detection [551]/[541]=3

[551]/[541]=004 Frequency detection $F_{out} < [611]$

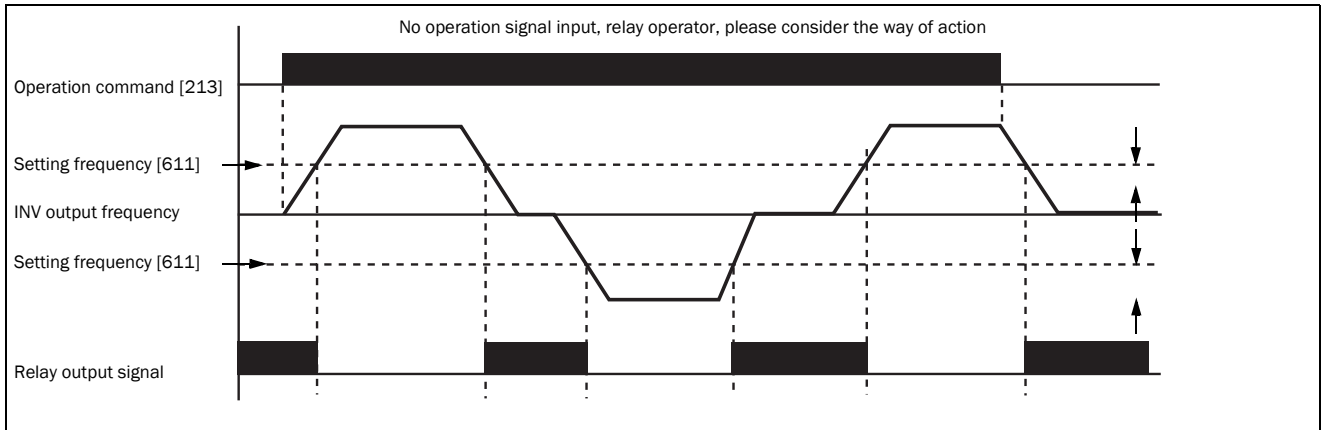

Fig. 38 Frequency Detection [551]/[541]=4)

[551]: Output current detection value $> [613]$ when setting value is 015.

[541]: Output current detection value $> [613]$ when setting value is 015.

When during running a fault situation appears, the output will be immediately de-activated.

When VSD is powered down, outputs will be de-activated.

[611] Preset Output frequency reached =00.0 to 200 Hz
 [612] Frequency detection range =00.0 to 30 Hz

[541] / [551] = 016 No Fault

Multi-function output RY1 and T+,T- are activated when the VSD is powered up and no fault situation occurs.

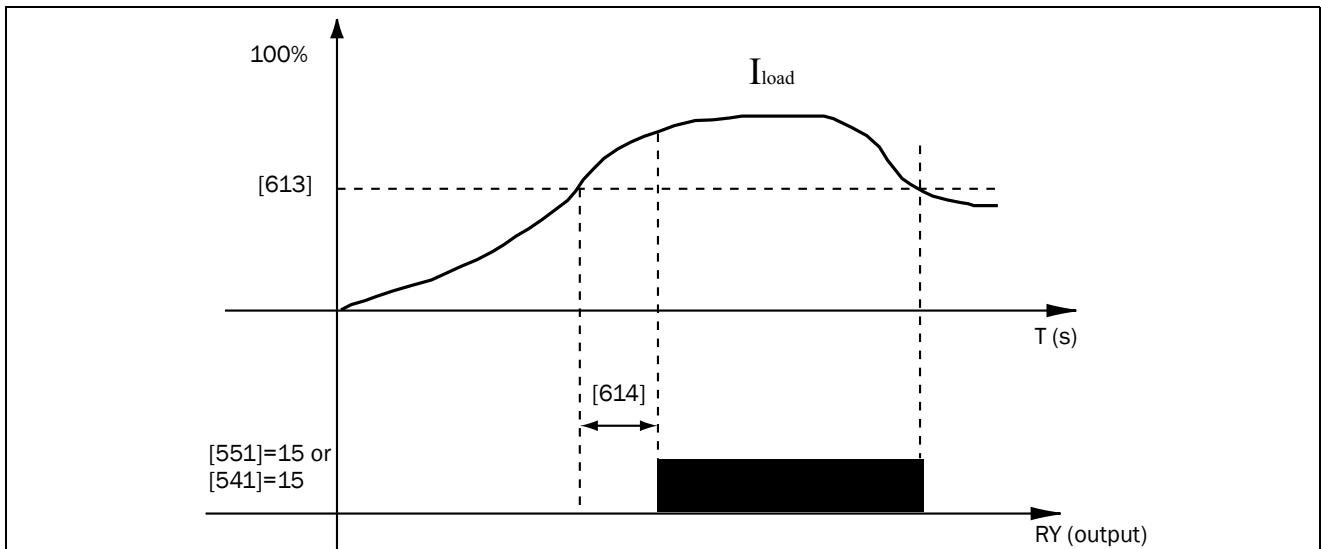

Fig. 39 Output current detection

613 Output current reached setting value

[613]: Setting value (000 to 100%) by motor rated current [223]

614 Output current detection time

[614]: Setting value (00.0 to 25.5) unit: seconds

811 Fault records (Latest 3 times)

Refer to section 4.1, page 57 for description of fault types.

921 VSD horse power capacity

921	VSD model	
01	VSA23-	01
03		03
04		04
07		07
10		10
002	VSA48-	002
004		004
005		005

922 Software version

4. Troubleshooting and maintenance

4.1 Trouble indication and corrective action

4.1.1 Fault/ Error display and Diagnostics

Un- reset able / un recoverable Errors

Display	Error	Cause	Corrective Action
EPR	EEPROM problem	EEPROM problem	Change EEPROM
@ OV	Over-voltage during stop	Voltage Detection circuit malfunction	Repair or replace unit
@ LV	Under-voltage during stop	1. Power voltage too low 2. Restraining resistor or fuse burnt out. 3. Detection circuit malfunctions	1. Check if the power voltage is correct or not 2. Replace the restraining resistor or the fuse 3. repair or replace unit
@ OH	The VSD is overheated during stop	1. Thermal Detection circuit malfunction 2. Ambient temperature too high or bad ventilation	1. Repair or replace unit 2. Improve ventilation conditions or relocate VSD
CTR	Current transducer detection error	Current transducer or circuit error.	Repair or replace unit

“@” the failure contact does not operate.

Errors which can be recovered both manually and automatically

Display	Error	Cause	Corrective Action
OCS	Over-current at start	1.Motor winding and frame short circuit 2.Motor and ground short circuit 3.Power module is damaged	1. Check the motor 2. Check the wiring 3. Replace the power module
OCD	Over-current at deceleration	The preset deceleration time is too short	Set a longer deceleration time
OCA	Over-current at acceleration	1. Acceleration time is too short 2. The capacity of the motor is higher than the capacity of the VSD 3.Short circuit between the motor winding and frame. 4.Short circuit between motor wiring and earth 5. IGBT module is damaged	1. Set a longer acceleration time 2. Replace the VSD with the same or greater capacity as that of the motor 3. Check the motor 4. Check the wiring 5. Replace the IGBT module
OCC	Over-current during run	1. Transient load change 2. Transient power change	Increase VSD capacity
OVC	Over-voltage during operation/ deceleration	1. Deceleration time setting is too short or excessive load inertia 2. Power voltage varies widely	1. Set a longer deceleration time 2. Add a braking resistor or braking unit 3. Add a reactor at the input line side 4.Increase VSD capacity
OHC	High heat sink temperature during operation	1. Heavy load 2. Ambient temperature too high or bad ventilation	1. Check if there are any problems with the load 2. Increase VSD capacity 3. Improve ventilation conditions 4. Inspect the setting value of parameter [217]

Errors which can only be recovered manually (no auto-restart)

Display	Error	Cause	Corrective Action
OC	Over-current during stop	1. OC Detection circuit malfunction 2. Bad connection for CT signal cable	Send the VSD back for repair
OL1	Motor overload	1. Heavy load 2. Improper settings of [223]	1. Increase motor capacity 2. Set [223] correctly according to motor name-plate.
OL2	VSD overload	Excessively heavy load	Increase VSD capacity
LVC	Under-voltage during operation	Power voltage too low Power voltage varies widely	1. Improve power quality. 2. Set a longer acceleration time Add a reactor at the power input side Contact technical support
COt	Communication time-out detection	1. [266] communication time-out detection time is too short. 2. VSD communication is defect. 3. VSD does not receive the correct Modbus data within the set detection time.	1. Increase [266] communication time-out detection time. 2. Repair VSD communication. 3. Check the Modbus data communication from the Master.

4.1.2 Set up configuration, interface errors

Display	Error	Description
SP0	Zero speed stop	Set frequency is <0.1Hz Increase set frequency
SP1	Fail to start directly	If the VSD is set to external control mode (213=001), and direct start is disabled (335=001), the VSD cannot be started and will flash STP1 when the Run switch is ON when applying power (see descriptions of 335). Direct start is possible when 335=000.
SP2	Keypad emergency stop	If the VSD is set to external control mode (213=001), the VSD will stop according to the setting of F9 when the stop key is pressed. STP2 flashes after stop. Turn the Run switch to OFF and then ON again to restart the VSD. 2. If the VSD is in communication mode and Stop key is enabled, the VSD will stop in the way set by F9 when Stop key is pressed during operation and then flashes STP2. The PC has to send a Stop command then a Run command to the VSD for it to be restarted.
E.S.	External emergency stop	The VSD will decelerate to stop and flashes E.S. when there is an external emergency stop signal via the multi-function input terminals (see descriptions of [521]~[524]).
b.b.	External base block	The VSD stops immediately and then flashes b.b. when external base block is input through the multi-functional input terminal (see descriptions of [521] to [524]).
PID	PID feedback signal loss	PID feedback signal circuit error detection
---	REMOTE KEYPAD cable broken	1. When REMOTE KEYPAD does not connect with VSD, this signal will be displayed on the Remote keypad. 2. When REMOTE KEYPAD connects with VSD, this signal will be displayed on the main keypad. 3. When both REMOTE KEYPAD and main KEYPAD display this signal means communication errors.

4.1.3 Keypad operation error description

Display	Error	Cause	Corrective Action
Er1	Key operation error	1. Attempt to Press + or - keys when [212]> 0 or in speed operation. 2. Attempt to modify parameters, which can not be modified during Run (see parameter list).	1. + or - keys can be used to modify frequencies only when [212]=0. 2. Modify parameters only in stop mode.
Er2	Parameter setting error	1. [344] is within ranges of [345]±[347] or [346]±[347] 2. [344]<[341] or [344]=[341]	1. Modify [366] to [367] 2. 3-00>3-01
Er5	Modification of parameter is not allowed during communication	1. Issue a control command during communication disabled 2. Modify [261] to [265] during communication.	1. Issue the enabling command before while communicating. 2. Set up parameters before communicating.
Er6	Communication error	1. Incorrect wiring. 2. Incorrect settings of communication parameters. 3. Check-sum error. 4. Incorrect communication verification.	1. Check the hardware and wiring. 2. Check [261] to [265]
Er7	Incorrect parameter settings	1. Attempt to modify [921] 2. Voltage and current detection circuits are malfunctioning.	Reset VSD or contact technical support
EP1	Parameter set error, Copy Unit failure	1. Set [241]=1.2, can not connect with Copy Unit. 2. Copy Unit failure. The voltage and drive rating on Copy Unit and the VSD are different.	1. Modify [241] Change Copy Unit Copy from keypad to VSD with only matched HP ratings
EP2	Parameters do not match	Copy the parameter to VSD to verify the parameter not matched.	Change Copy Unit The voltage and HP rating of Copy Unit is different than the VSD.

4.1.4 Load monitor error description

Table 1

Display	Error	Cause	Corrective Action
ut	Trip for underload	Minimum load alarm level (underload) has been reached.	1. Check the load condition of the machine. 2. Check the monitor setting in [411] to [429].
Put	Pre-alarm underload	Actual load reaches minimum pre-alarm margin.	1. Check the load condition of the machine. 2. Check the monitor setting in [411] to [429].
Ot	Trip for overload	Maximum load alarm level (overload) has been reached.	1. Check the load condition of the machine. 2. Check the monitor setting in [411] to [429].
Pot	Pre-alarm overload	Actual load reaches maximum pre-alarm margin.	1. Check the load condition of the machine. 2. Check the monitor setting in [411] to [429].

4.2 General functional troubleshooting

Status	Checking point	Corrective Action
Motor does not run	Is power applied to L1, L2, and L3(N) terminals (is the charging indicator lit)?	Is the power applied? Turn the power OFF and then ON again. Make sure the input line voltage is correct. Make sure all terminal screws are secured firmly.
	Are there voltage outputs on T1, T2, and T3 terminals?	Turn the power OFF and then ON again.
	Is the motor mechanically overloaded?	Reduce the load to improve performance.
	Are there any problems with the VSD?	See error descriptions to check wiring and correct if necessary.
	Has the forward or reverse run commands been issued?	
	Is there an analogue input signal?	Is analogue frequency input signal wiring correct? Is frequency input voltage correct?
	Is operation mode setting correct?	Configure operations through the digital panel
Motor rotates in the wrong direction	Are wiring for output terminals T1, T2, and T3 correct?	Wiring must match U, V, and W terminals of the motor.
	Are wiring for forward and reverse signals correct?	Check wiring and correct if necessary.
Motor rotates in the wrong direction The motor speed can not vary	Are wiring for output terminals T1, T2, and T3 correct?	Check wiring and correct if necessary.
	Is the setting of frequency command source correct?	Check the operation mode setting on the keypad.
	Is the load too large?	Reduce the applied load.
Motor running at too high or too low speeds.	Is the setting of operation mode correct?	Confirm the motor's specifications.
	Is the load too large?	Confirm the gear ratio.
	Are specifications of the motor (poles, voltage...) correct?	Confirm the highest output frequency.
Motor speed is incorrect or erratic	Is the gear ratio correct?	Reduce the load.
	Is the setting of the highest output frequency correct?	Minimize the variation of the load. Increase capacities of the VSD and the motor.
	Is the load too large?	Add an AC reactor at the power input side if using single-phase power. Check wiring if using three-phase power.

4.2.1 Troubleshooting flowcharts VSA series

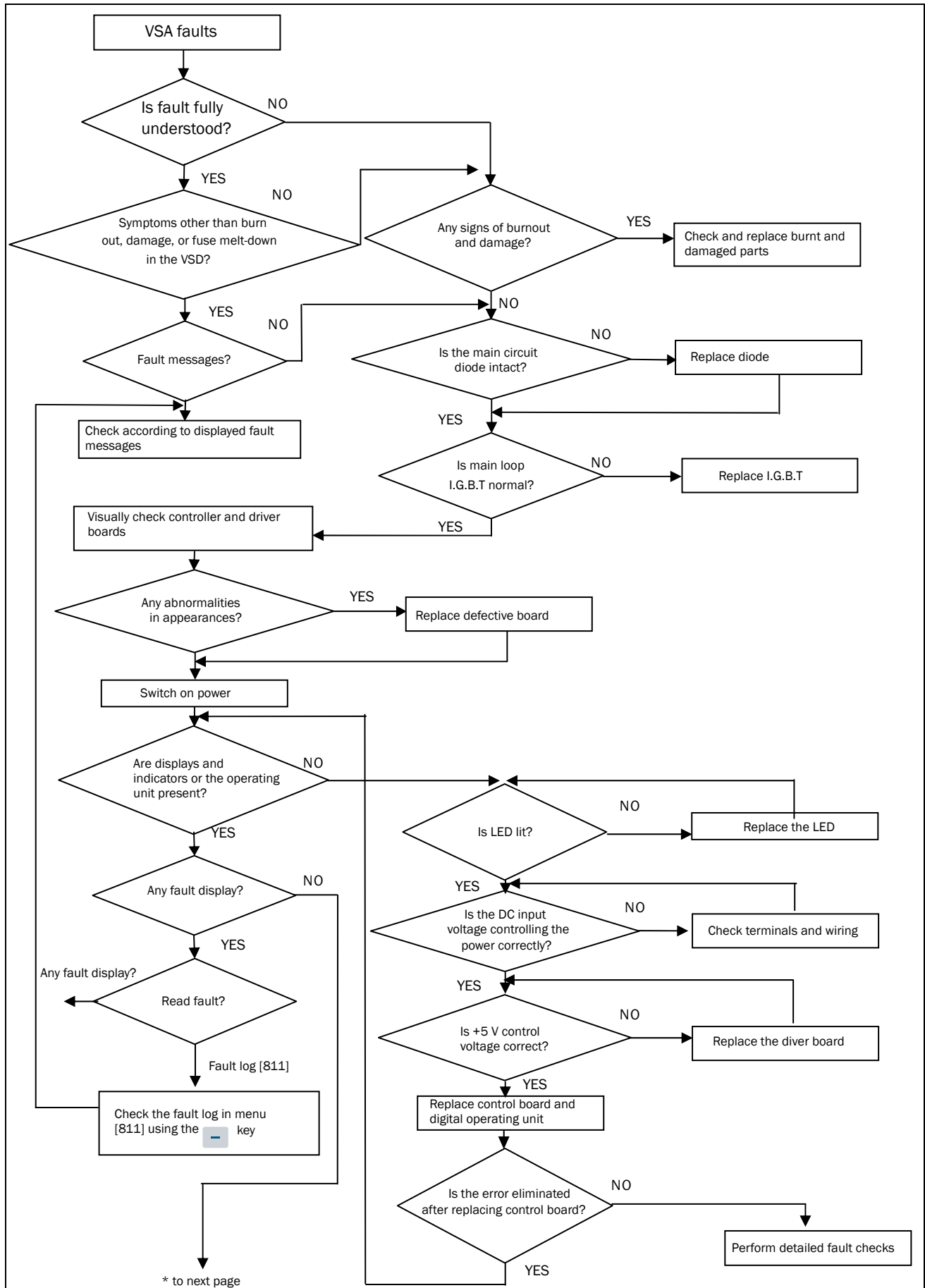

Fig. 40 General troubleshooting flowchart

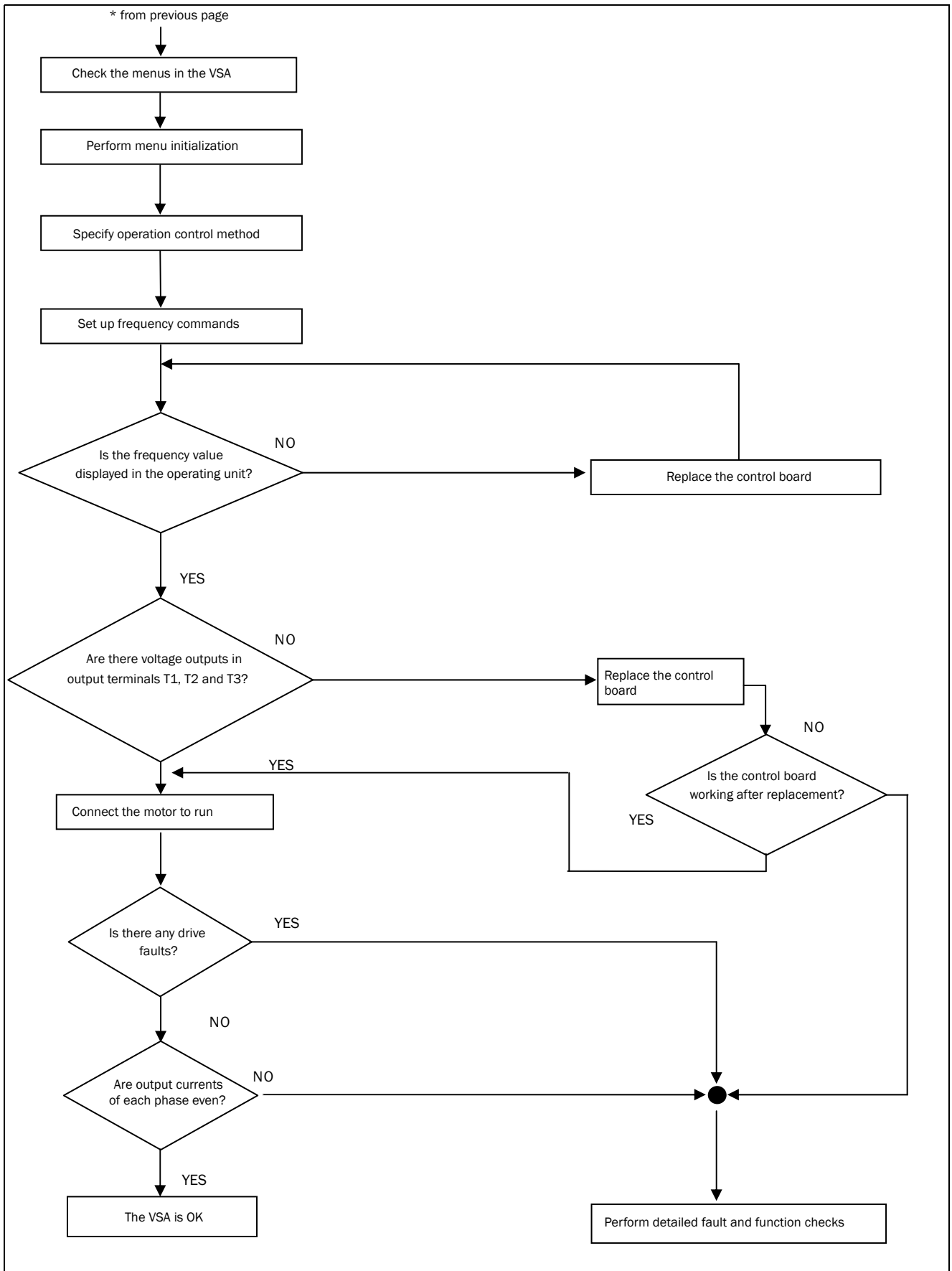

Fig. 41 General troubleshooting flowchart, CONTD

Troubleshooting for OC, OL error displays

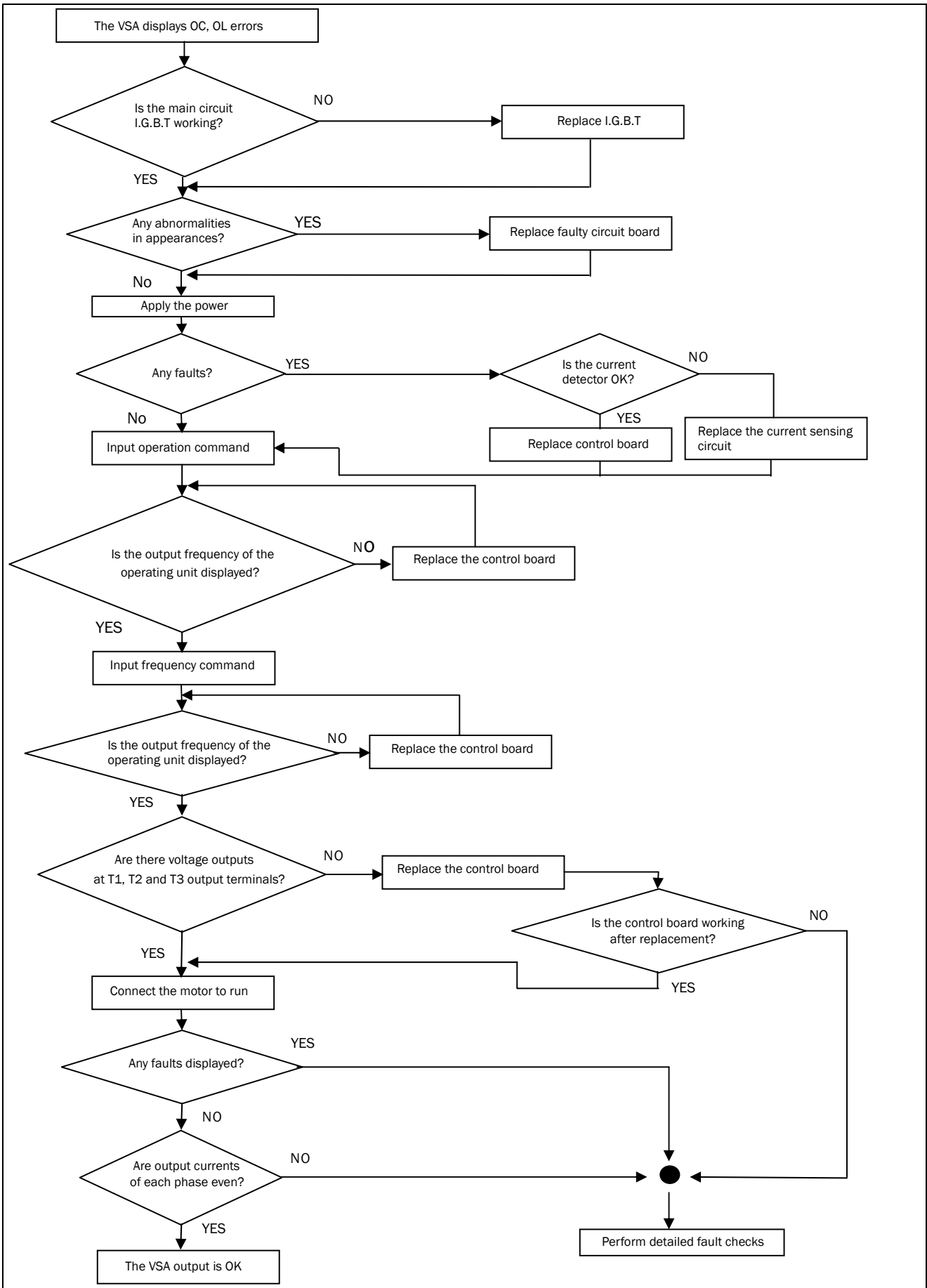

Fig. 42 OC, OL fault troubleshooting

Troubleshooting for OV, LV error display

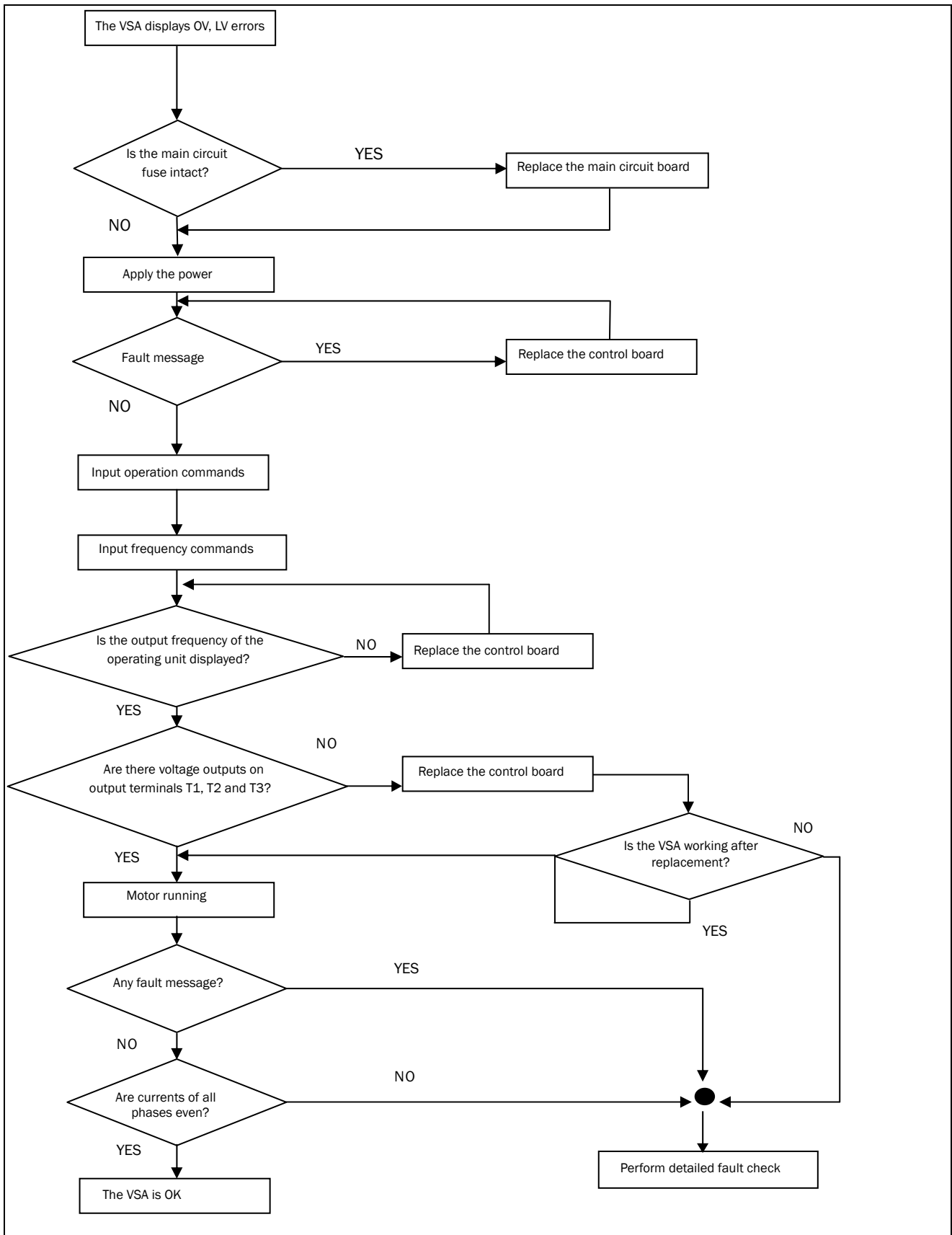

Fig. 43 OV fault troubleshooting

Motor does not run

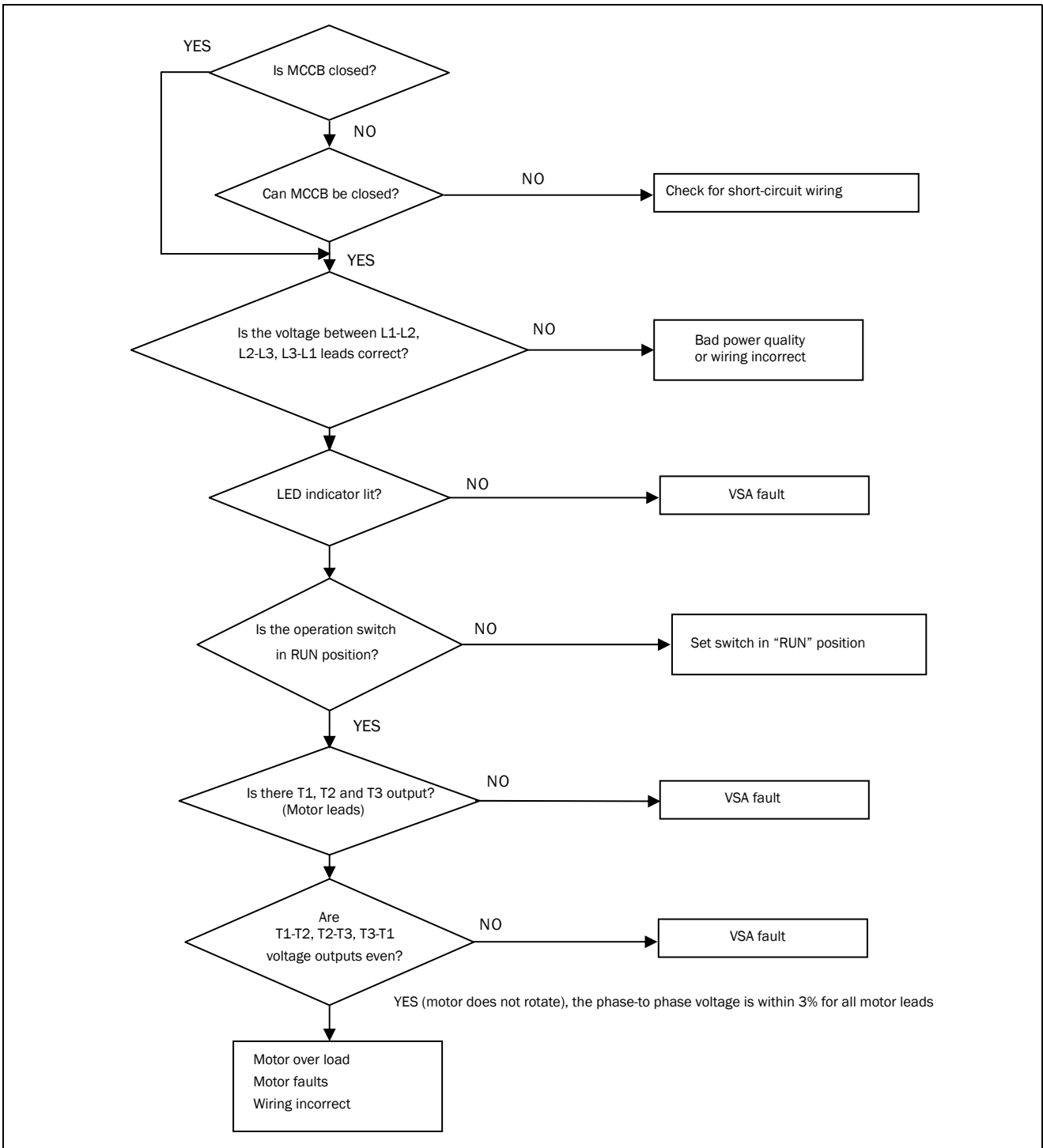

Fig. 44 Drive running troubleshooting diagnostics

Motor is overheated

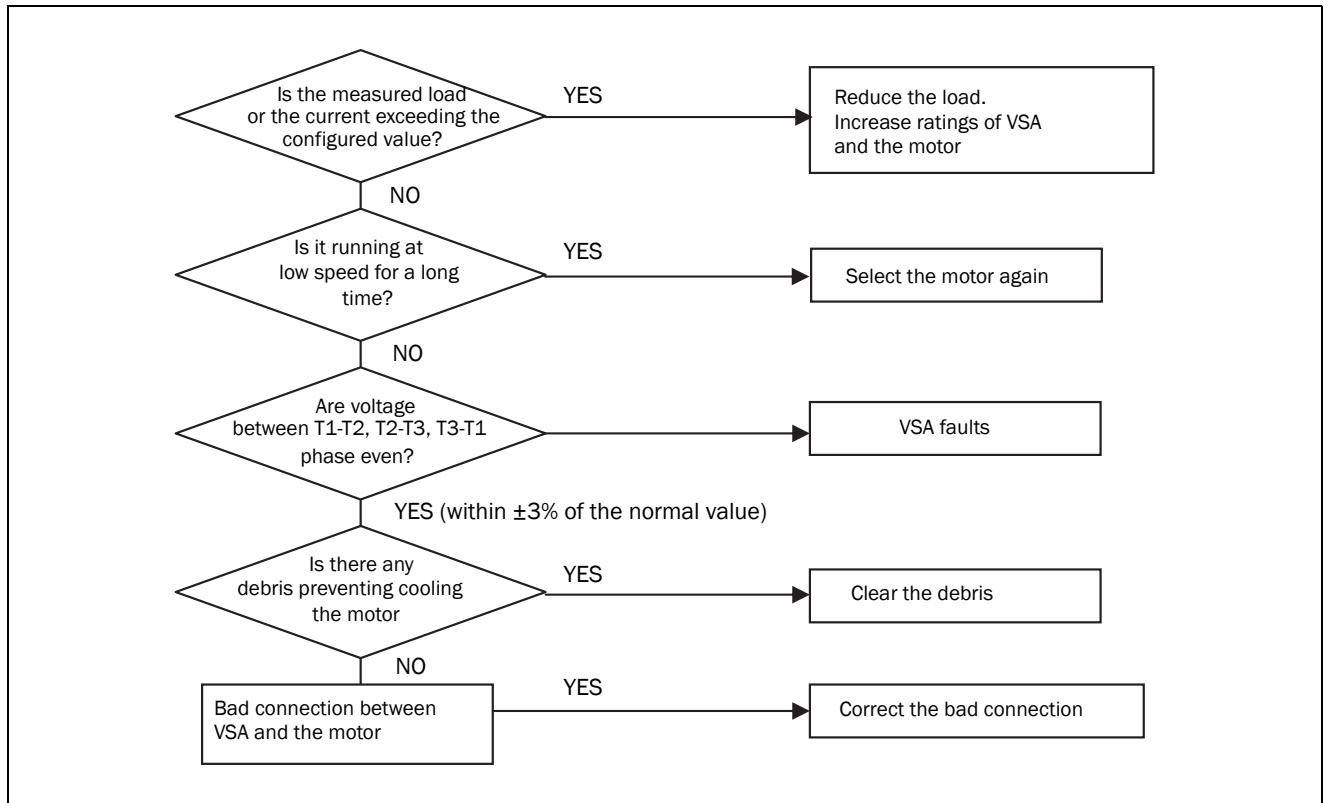

Fig. 45 Motor Overload/Overheating Diagnostics

Motor runs unevenly

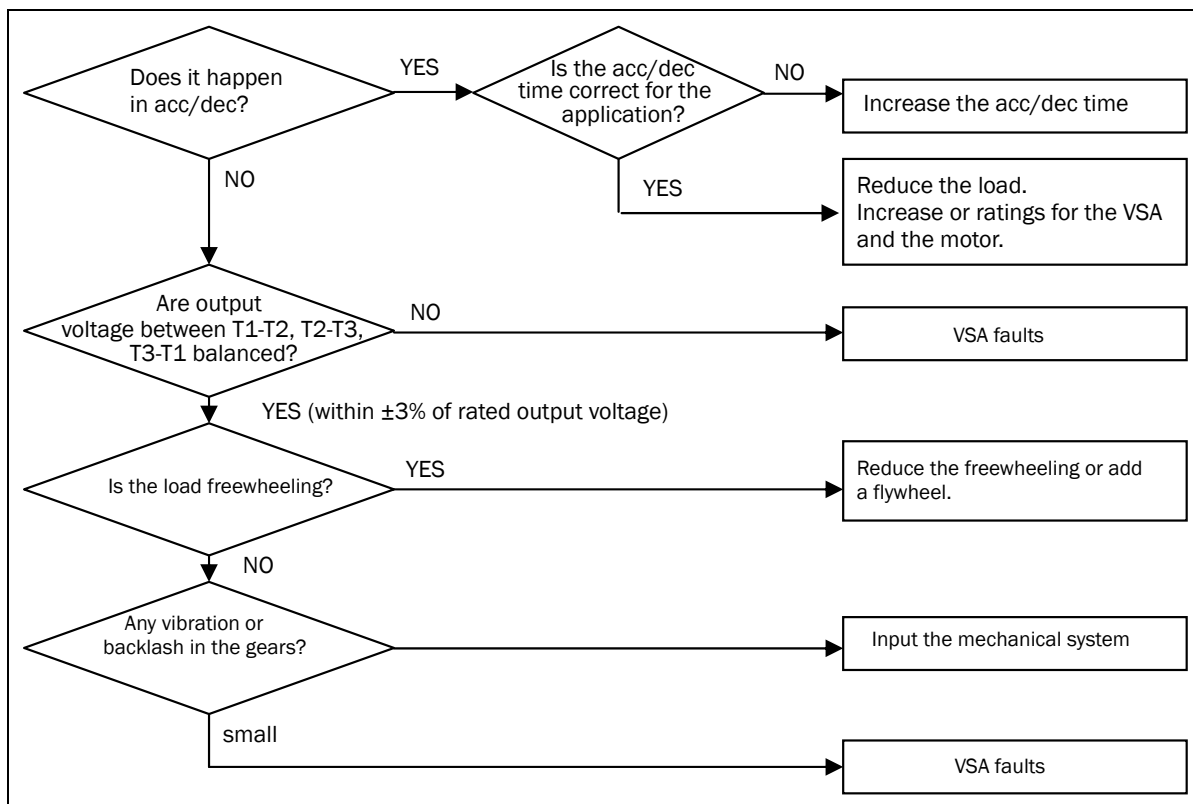

Fig. 46 Uneven Speed Operation Diagnostics

4.3 Routine and periodic checks

To ensure stable and safe operations, check and maintain the VSD regularly and periodically.

The table below lists the items to be check to ensure stable and safe operations.

Check these items 5 minutes after the “Charge” indicator goes out to prevent injury to personnel.

Items	Details	Checking period		Methods	Criteria	Remedies
		Daily	1 year			
Ambient conditions around the machine	Confirm the temperature and humidity at the machine	<input type="radio"/>		Measure with thermometer and hygrometer according to installation notices.	Temperature: -10 – 50°C (14 to 120°F) Humidity: Below 95% RH	Improve the ambient or relocate the drive to improve the conditions.
	Are there inflammable materials in the vicinity?	<input type="radio"/>		Visual check	Keep area clear	
Installation and grounding of the VSD	Any unusual vibration from the machine	<input type="radio"/>		Visual, hearing check	No vibration	Secure screws
	Is the grounding resistance correct?		<input type="radio"/>	Measure the resistance with the Ground Resistor	200 V series: below 100 400 V series: below 10	Improve the grounding
Input power voltage	Is the voltage of the main circuit correct?	<input type="radio"/>		Measure the voltage with a multi-tester	Voltage must conform with the specifications	Improve input voltage
External terminals and internal mounting screws of the VSD	Are secure parts loose?		<input type="radio"/>	Visual check Check with a screwdriver	Secure terminals and no rust	Secure or send back for repair
	Is the terminal base damaged?		<input type="radio"/>			
	Visual rust stains present?		<input type="radio"/>			
Internal wiring of the VSD	Any unusual bends or breaks?		<input type="radio"/>	Visual check	No abnormalities	Replace or send back for repair
	Any damage of the wire insulation?		<input type="radio"/>			
Heat sink	Excessive dust or debris?	<input type="radio"/>		Visual check	No abnormalities	Clean up debris or dust
Printed circuit board	Conductive metal shavings or oil sludge present?		<input type="radio"/>	Visual check	No abnormalities	Clean or replace the circuit board
	Discoloured, overheated, or burned parts		<input type="radio"/>			
Cooling fan	Unusual vibration and noise		<input type="radio"/>	Visual or hearing check	No abnormalities	Replace the cooling fan
	Excessive dust or debris?	<input type="radio"/>		Visual check		Clean fan
Power component	Excessive dust or debris?		<input type="radio"/>	Visual check	No abnormalities	Clean component
	Check resistance between each terminals		<input type="radio"/>	Measure with a multi-tester	No short circuit or broken circuit in three-phase output	Replace power component or VSD
Capacitor	Any unusual odour or leakage	<input type="radio"/>		Visual check	No abnormalities	Replace capacitor or VSD
	Any deformity or protrusion	<input type="radio"/>				

5. Peripherals

5.1 Input side AC reactor

Model		Line input side AC inductance	
		Current (A)	inductance (mH)
VSA	23-01	5.0	2.1
	23-03	5.0	2.1
	23-04	19.0	1.1
	23-07	25.0	0.71
	48-002	2.5	8.4
	48-004	5.0	4.2
	48-005	7.5	3.6

Fig. 47 External Filter Dimensions for VSA23-07 and VSA23-10

5.2 Option card

5.2.1 RS-485 option card

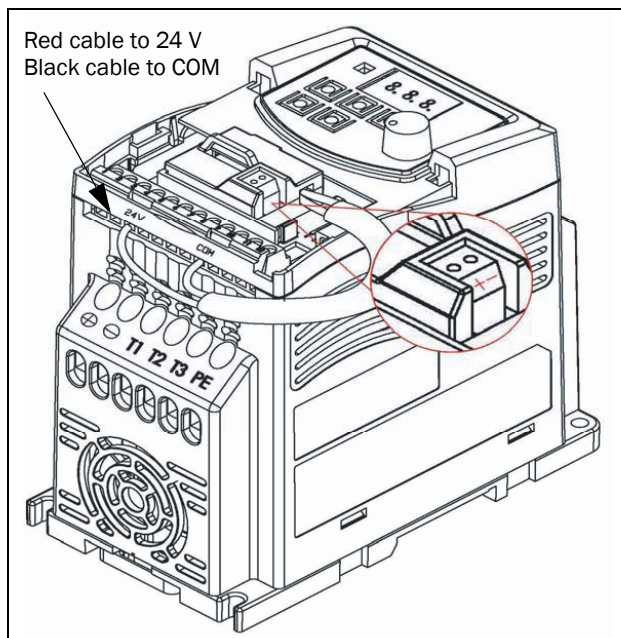

Fig. 48 RS485 module

RS485 wiring diagram:

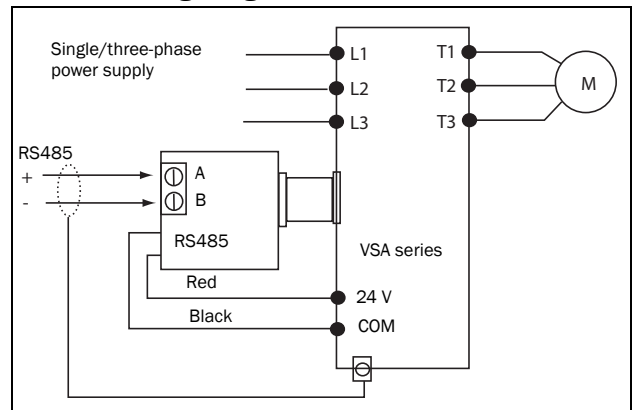

Fig. 49 RS485 wiring diagram

NOTE: In order to avoid external static electricity interference with option cards function, please replace cover of the VSD after installing option cards.

Please use isolated RS232/RS485 converter connections with PC and option card to avoid equipment damage.

5.2.2 RS-232 option card

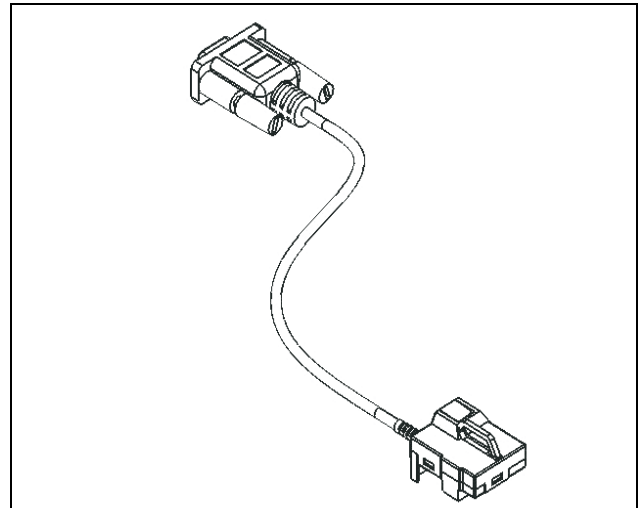

Fig. 50 RS232 cable

RS232 wiring diagram

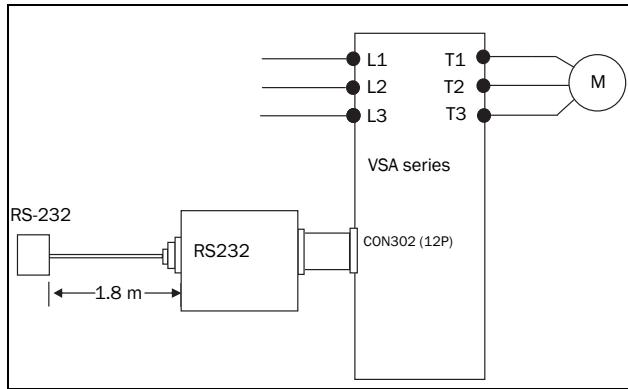

Fig. 51 JNSIF-232 wiring diagram

5.2.3 Program copy option card

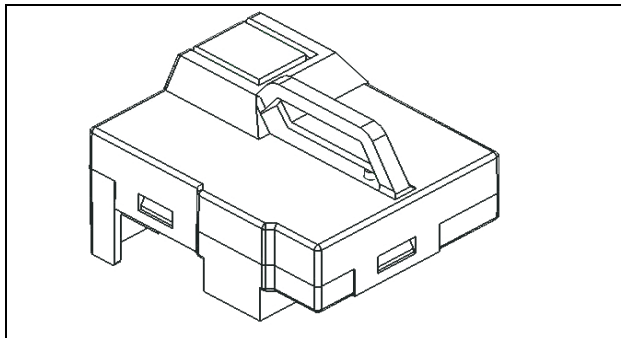

Fig. 52 Memory pack module

Memory pack wiring diagram

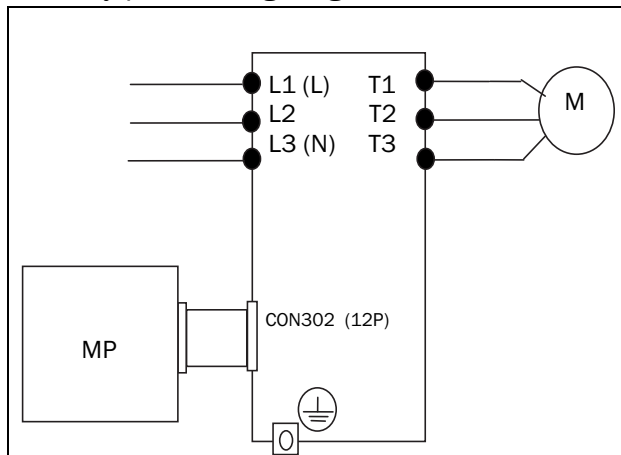

Fig. 53 Memory pack wiring diagram

5.2.4 Remote keypad

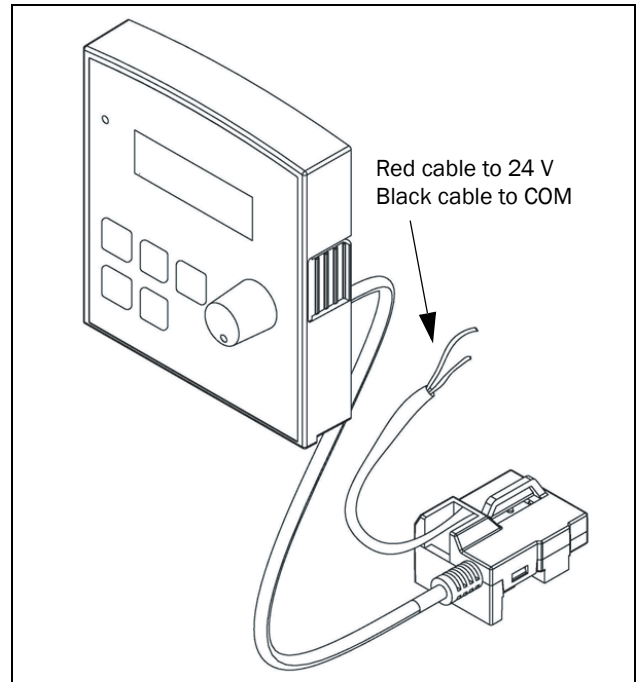

Fig. 54 Remote keypad

Remote keypad wiring diagram

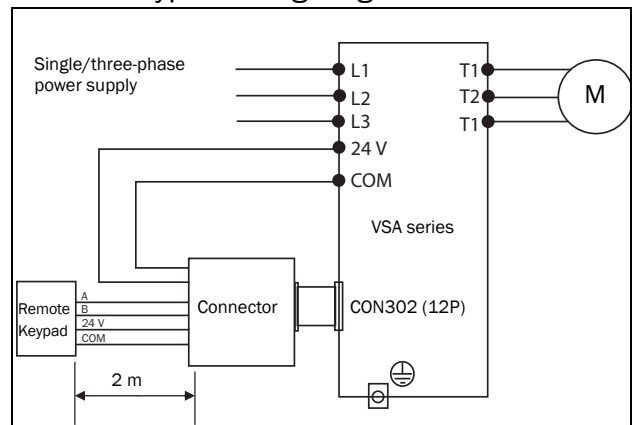

Fig. 55 Remote keypad Wiring Diagram

* When the VSD is powered on or off the user can set up or remove the remote keypad. (Must be in remote terminal configuration)

5.2.5 Input/Output expansion card

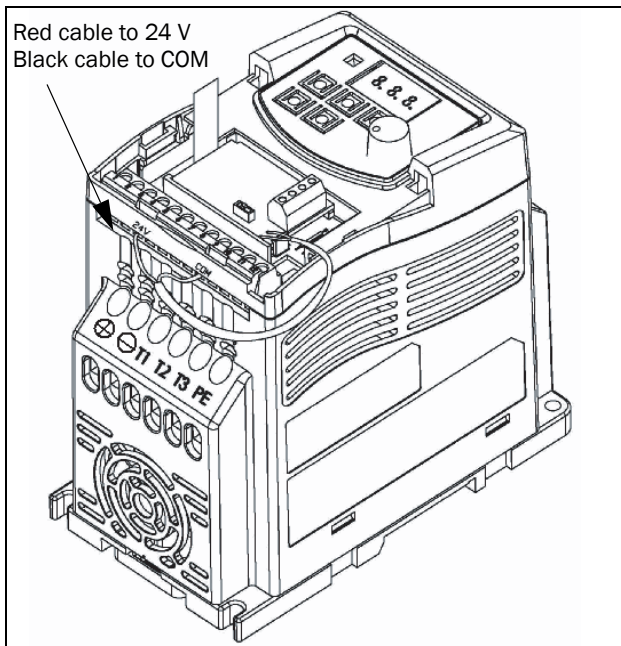

Fig. 56 IO card

IO wiring diagram

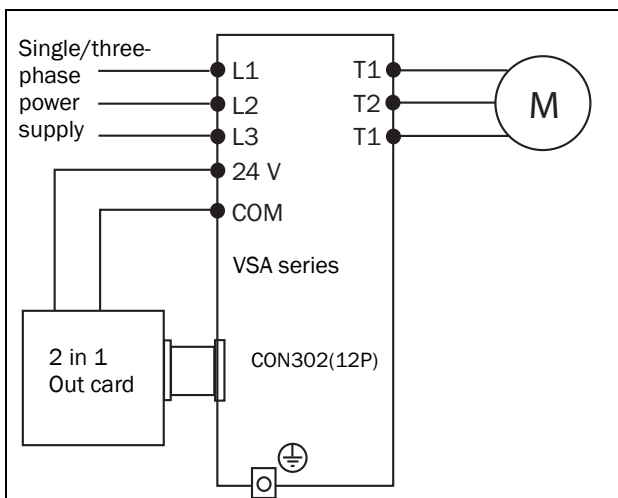

Fig. 57 IO Wiring Diagram

6. Appendix VSA parameter list

Customer Name		Model of the VSD:			
Menu	Setting	Menu	Setting	Menu	Setting
110		337		418	
211		338		419	
212		339		41A	
213		33A		41B	
214		341		41C	
215		342		41D	
216		343		41E	
217		344		41F	
218		345		421	
219		346		422	
221		347		423	
222		348		424	
223		351		425	
224		352		426	
225		353		427	
226		354		428	
231		355		429	
232		356		432	
233		357		433	
234		358		511	
235		359		512	
236		35A		513	
237		35B		514	
238		35C		515	
239		361		516	
241		362		517	
242		363		518	
251		364		521	
252		365		522	
261		366		523	
262		367		524	
263		368		525	
264		369		526	
265		381		531	
266		382		532	
267		383		541	
321		384		551	
322		385		611	
323		411		612	

331		412		613	
332		413		614	
333		414		811	
334		415		921	
335		416		922	
336		417			



DEDICATED DRIVE

Emotron AB, Mörsaregatan 12, SE-250 24 Helsingborg, Sweden

Tel: +46 42 16 99 00, Fax: +46 42 16 99 49

E-mail: info@emotron.se

Internet: www.emotron.com